

General Information Body Repairs, General Body Repairs

Edition 06.2018



ŠKODA

Protected by copyright. Copying for private or commercial purposes, in part or in whole, is not permitted unless authorised by ŠKODA AUTO A. S. ŠKODA AUTO A. S. does not guarantee or accept any liability with respect to the correctness of information in this document. Copyright by ŠKODA AUTO A. S.

Repair Group



Technical information should always be available to the foremen and mechanics, because their careful and constant adherence to the instructions is essential to ensure vehicle road-worthiness and safety. In addition, the normal basic safety precautions for working on motor vehicles must, as a matter of course, be observed.

Protected by copyright. Copying for private or commercial purposes, in part or in whole, is not permitted unless authorised by SKODA AUTO A. S. SKODA AUTO A. S. does not guarantee or accept any liability to the correctness of information in this document. Copyright by ŠKODA AUTO A. S.

**All rights reserved.
No reproduction without prior agreement from publisher.**



Contents

1	Safety measures	1
1.1	Fuel tanks and fuel-carrying lines.	1
1.2	Air Conditioning	1
1.3	Electronic control units	2
1.4	Battery	2
1.5	High-voltage conducting components / electric motors	3
1.6	Safety instructions when performing repair work in bodysells and liquefied petroleum gas systems (LPG)	3
1.7	Safety instructions	4
1.8	Safety measures	4
1.9	Working on the alignment frame	4
1.10	Disassembly of parts	4
1.11	Welding work	5
1.12	Paintwork, glass, upholstery, trims	5
1.13	Airbag system	5
1.14	Safety instructions for belt tensioners	5
1.15	Warning signs	5
2	Fundamentals of bodywork repairs	6
2.1	Fundamentals of bodywork repair	6
2.2	Galvanised body parts	6
2.3	Removing residues	7
2.4	New parts	7
2.5	Foam moulds	8
2.6	Original welding	8
2.7	Diagnosis of accident vehicles	8
2.8	Finishing work on the body	9
2.9	Repairing higher-strength body panels	9
2.10	High-strength/ultra-strength, warm-formed body panels	10
2.11	Body Work - Glued joints	11
2.12	Removing underbody protection and sealing seams	12
3	Explanation of symbols	14
3.1	Symbols, structure	14
3.2	Symbols, preparation	15
3.3	Symbols, welding	16
3.4	Symbols, riveting	17
3.5	Symbols, corrosion protection	18
4	Vehicle body structure features	19
4.1	Multimedia mix	19
5	Damage assessment	20
5.1	General points	20
5.2	Check weld seams and body connections	20
5.3	Force reduction during impact	20
5.4	Measuring methods / damage diagnostics	23
5.5	Overview of the materials used	23
5.6	Passive safety	25
6	Methods of thermal connection	26
6.1	Methods of thermal connection	26
6.2	Spot welding (RP)	26
6.3	Hole seams - shielding gas	27
6.4	Seal with SG full seam (shielding gas) and quilting seam	28
6.5	MIG welding	29
6.6	Laser welding	30
6.7	Laser soldering	30



6.8	Replacement gap method during repair (steel)	31
7	Cold connection methods	32
7.1	Gluing	32
7.2	Rivet	32
7.3	Overview - Pairing riveting tools	37
7.4	FDS screws (flow drill screws)	38
7.5	Pressing through	39
8	Cutting techniques for body repairs; areas of application	40
8.1	Bore	40
8.2	Cutting	40
8.3	Sanding	40
8.4	Milling	41
8.5	Remove adhesive bonds	41
9	Repairing surfaces	42
9.1	Bulking sheet steel techniques	42
9.2	Metal and aluminium mastic	43
9.3	Lead-free tin processing	43
9.4	Definition of "properly shaped surface" / Delivery to the paint shop	44
10	Straightening the vehicle	45
10.1	Alignment	45
10.2	Separation cuts	45
10.3	Bodyshell offcut sections and parts	45
11	Corrosion prevention	46
11.1	Long-term body protection	46
11.2	Body long-term protection if filling is needed	46
12	Plastic repair	47
12.1	Plastic repair	47
12.2	Repairing indentations	47
12.3	Repairing scratches	49
12.4	Repairing a crack (up to 100 mm length)	50
12.5	Repairing a hole (up to 30 mm diameter)	51
12.6	Plastic repair (GRP)	52
13	Glass repair	55
13.1	Front window repair	55
14	Repairing thread	57
14.1	Repairing thread	57
15	Repairing the thread for the attachment of the assembly carrier	58
15.1	Repairing the thread for the attachment of the assembly carrier	58
15.2	Contents of the thread repair set	60
15.3	Drilling thread	60
15.4	Cutting the thread	61
15.5	Inserting the threaded insert	62
16	Tools	64
16.1	List of tools	64
17	Decorative and protective foils	65
17.1	Decorative and protective foils	65
17.2	Training videos	65

1 Safety measures

(SKAH000008; Edition 06.2018)

- ⇒ [“1.1 Fuel tanks and fuel-carrying lines.”, page 1](#)
- ⇒ [“1.2 Air Conditioning”, page 1](#)
- ⇒ [“1.3 Electronic control units”, page 2](#)
- ⇒ [“1.4 Battery”, page 2](#)
- ⇒ [“1.5 High-voltage conducting components / electric motors”, page 3](#)
- ⇒ [“1.6 Safety instructions when performing repair work in body-shells and liquefied petroleum gas systems \(LPG\)”, page 3](#)
- ⇒ [“1.7 Safety instructions”, page 4](#)
- ⇒ [“1.8 Safety measures”, page 4](#)
- ⇒ [“1.9 Working on the alignment frame”, page 4](#)
- ⇒ [“1.10 Disassembly of parts”, page 4](#)
- ⇒ [“1.11 Welding work”, page 5](#)
- ⇒ [“1.12 Paintwork, glass, upholstery, trims”, page 5](#)
- ⇒ [“1.13 Airbag system”, page 5](#)
- ⇒ [“1.14 Safety instructions for belt tensioners”, page 5](#)
- ⇒ [“1.15 Warning signs”, page 5](#)

Protection for commercial purposes, in part or in whole, is not permitted unless authorised by SKODA AUTO A. S. SKODA AUTO A. S. does not guarantee or accept any liability with regard to the accuracy of the information.

1.1 Fuel tanks and fuel-carrying lines.

When carrying out grinding and welding work in the areas of the fuel tank or other fuel-carrying parts, you are advised to exercise extreme caution. In case of doubt, such parts must be dismantled. The fuel tank and the fuel lines which are removed from the vehicle must be stored in accordance with the relevant safety instructions.

1.2 Air Conditioning

Do not perform any welding work - hard or soft- on parts of the filled air conditioning unit. This rule holds for welding and soldering work where there is the risk that parts of the Air Conditioning may heat up. When making paintwork repairs, temperatures in the drying oven must not exceed max. 80 °C, because heating causes a large overpressure in the system that may cause the system to explode.



Note

- ◆ *You need to suction off the refrigerant circuit when electrical welding is needed close to refrigerant lines. During electrical welding, invisible UV rays may be released which can penetrate the refrigerant lines and destroy the refrigerant.*
- ◆ *Suction off the refrigerant ⇒ Heating, Air Conditioning; Rep. gr. 87.*

An Air Conditioning unit which has been emptied can only be filled by a A/C service station. For this reason only empty the Air Conditioning when required by the safety measures.

When carrying out repairs to the vehicle, the refrigerant circuit must be emptied. Avoid any contact with liquid refrigerant or refrigerant vapours.



Protect your hands and eyes with safety goggles and rubber gloves. Frostbites arise due to intensive action on unprotected body parts.



WARNING

It is recommended to hold an eye bath flask within reach. If liquid refrigerant gets into the eyes rinse the eyes out thoroughly with water for approximately 15 minutes. Subsequently apply eye drops and immediately contact a physician, even if the eyes are not painful. Inform the doctor that the frostbites were caused by refrigerant R12 or R134a. If in spite of these safety measures, the refrigerant comes into contact with other body parts, immediately and thoroughly rinse the area with cold water for at least 15 minutes.

Though the refrigerant is not a fire hazard, please do not smoke in a suffused with refrigerant. The refrigerant gas is split chemically by the high temperatures from a burning cigarette. Inhaling the resulting poisonous fission products leads to chesty coughs and nausea.

1.3 Electronic control units

Connect the earth connection of the electric welding tool directly to the part to be welded. When doing so, make sure that there aren't any insulated parts between the earth connection and welding point.

Electronic control units and electrical wiring must not touch the earth connection or the welding electrode.

Working with electronic control units when performing repairs after accidents

Electronic control units must only be replaced when at least one of the following conditions has been met:

- The housing is noticeably deformed or damaged.
- The contact surface or the console is deformed but the control unit is not damaged from the outside.
- The connectors are damaged or corroded by moisture.
- When performing a functional test or during self-diagnosis, the following error "Control unit defective" arises.

When electronic components, such as the control unit for ABS, were removed during repair work and then reused, these must undergo a functional test before assembly, e.g. by self-diagnosis.

1.4 Battery



Note

Disconnect the battery to check if an encoded radio is installed. Before transferring the vehicle to the customer radio, enter the correct code number.

Before welding, always remove both battery terminals and cover the battery poles.

Always remove the vehicle battery before performing any work which induces sparking.

Protected by copyright. Copying for private or commercial purposes, in part or in whole, is not permitted without the prior written consent of ŠKODA AUTO A. S. ŠKODA AUTO A. S. does not guarantee or accept any liability with respect to the correctness of information in this document. Copyright by ŠKODA AUTO A. S.



 Note

Before disconnecting the battery, read the vehicle-specific remarks in the repair booklet! ⇒ Electrical System; Rep. gr. 27.

1.5 High-voltage conducting components / electric motors



DANGER!

Service, installation and repair work on high-voltage-conducting components/electromobiles as well as their inspections must only be carried out by properly qualified personnel according to the relevant national legislation and standards!

Refer to vehicle-specific repair instructions for information.

1.6 Safety instructions when performing repair work in bodysells and liquefied petroleum gas systems (LPG)



WARNING

Service, installation and repair work on the liquefied petroleum gas system as well as their inspections must only be carried out by properly qualified personnel according to the relevant national legislation and standards!

Service, installation and repair work on the natural gas system as well as their inspections must only be carried out by specialist garages with suitable safety elements according to the relevant national legislation and standards!

Valid instructions, regulations, standards and recommendations for service, assembly and repair work on the natural gas system, as well as checks, must be obtained from the importer in the applicable country.

Refer to vehicle-specific repair instructions for information.

⇒ Engine; 00 technical data; safety instructions

⇒ Engine; 00 Specifications; CNG - General information

ŠKODA

Protected by copyright. Copying for private or commercial purposes, in part or in whole, is not permitted unless authorised by ŠKODA AUTO A. S. ŠKODA AUTO A. S. does not guarantee or accept any liability with respect to the correctness of information in this document. Copyright by ŠKODA AUTO A. S.



WARNING

All activities with a risk of inflammation (e.g. Car body work such as grinding and welding, with risk of damage to the natural gas container (e.g. car body work in the area of the natural gas container) or varnish repairs at temperatures above 60 ° C measured at the natural gas containers, with the risk of damage to the natural gas tank, are only possible after the expansion of the natural gas containers on the basis of the procedure prescribed by the vehicle manufacturer.

In the case of working with heat (e.g. combustion booth), measures must be taken according to the specifications of the vehicle manufacturer, For example, a pressure reduction of the natural gas drive system must be carried out according to the manufacturer's specifications. The temperature of the natural gas containers shall not exceed 60 ° C, unless otherwise specified by the manufacturer.

1.7 Safety instructions

The special country-specific safety instructions must be followed for all of the work described. In case of doubt, seek information from the appropriate departments.

1.8 Safety measures

With all work, carry out the personal and general safety measures required by law. This includes wearing glasses, gloves, safety boots and hearing protection, for example.

1.9 Working on the alignment frame

When aligning a bodyshell damaged through an accident, very high forces act on the bodyshell using compressed air- or tensile devices on the alignment frame. These forces can suddenly be released at any time e.g. due to a fastening claw slipping.

For this reason make sure no person is present in the immediate danger area.

1.10 Disassembly of parts

Secure the vehicle on the lift platform before its centre of gravity shifts considerably because of successive disassembly operations.

Raise vehicle ⇒ Maintenance ; Booklet ŠKODA

Protected by copyright. Copying for private or commercial purposes, in part or in whole, is not permitted unless authorised by ŠKODA AUTO A. S. ŠKODA AUTO A. S. does not guarantee or accept any liability with respect to the correctness of information in this document. Copyright by ŠKODA AUTO A. S.

1.11 Welding work



Caution

Toxic Zinc oxide arises when welding galvanized steel sheets. For this reason, ensure that the working environment is well ventilated and there are suitable exhaust extraction systems to remove smoke gas, e.g. -V.A.G 1586 A-. Whenever carrying out welding work on the vehicle, the working area on the vehicle must be shielded from the rest of the vehicle with flame-proof covers or mats. If this step has been carried out properly, it will not be necessary to remove the entire vehicle interior. A fire extinguisher must be immediately accessible as a safety precaution. If the welding assembler is not able to monitor the vehicle, a second person must be asked to help. The gases arising during welding work are toxic and must be removed by extraction.



Note

- ◆ Remove the battery before carrying out all welding work.
- ◆ Disconnect the alternator.

1.12 Paintwork, glass, upholstery, trims

In rooms used for bodyshell repairs, do not park any other vehicles unless protected (risk of fire due to flying sparks or battery and also paintwork and/or glass damage etc).

1.13 Airbag system

Safety measures ⇒ Body Work; Rep. gr. 69 .

Repair work ⇒ Body Work; Rep. gr. 69 .

1.14 Safety instructions for belt tensioners

Safety measures ⇒ Body Work; Rep. gr. 69 .



WARNING

Belt tensioner units must be removed from the vehicle prior to performing cutting, alignment, knocking out work in their close proximity. If the belt tensioners were triggered during an accident, the safety belts must be replaced.



Note

The seat belt system must be inspected systematically after every accident! Replace any seatbelts which are found to be damaged ⇒ Body Work; Rep. gr. 69 .

1.15 Warning signs

If the warning signs are damaged or were removed, e.g. during a parts replacement, attach new original warning signs to them.



2 Fundamentals of bodywork repairs

- ⇒ [“2.1 Fundamentals of bodywork repair”, page 6](#)
- ⇒ [“2.2 Galvanised body parts”, page 6](#)
- ⇒ [“2.3 Removing residues”, page 7](#)
- ⇒ [“2.4 New parts”, page 7](#)
- ⇒ [“2.5 Foam moulds”, page 8](#)
- ⇒ [“2.6 Original welding”, page 8](#)
- ⇒ [“2.7 Diagnosis of accident vehicles”, page 8](#)
- ⇒ [“2.8 Finishing work on the body”, page 9](#)
- ⇒ [“2.9 Repairing higher-strength body panels”, page 9](#)
- ⇒ [“2.10 High-strength/ultra-strength, warm-formed body panels”, page 10](#)
- ⇒ [“2.11 Body Work - Glued joints”, page 11](#)
- ⇒ [“2.12 Removing underbody protection and sealing seams”, page 12](#)

2.1 Fundamentals of bodywork repair

Only selected work steps are described in this Workshop Manual.

For the steps not described, undo the original welding and replace it with a repair part.

Methods and procedures deviating from the original welding are described in the Bodysshell repair Workshop Manual.

Damaged outer parts (sheets) of the body are removed depending on the extent of the damage. An exception is the body roof, which is always replaced in full.

Delivered blank parts must be cut to size, adjusted and butt welded depending on the damage, inert gas-shielded full seam (protective gas).

2.2 Galvanised body parts



WARNING

Toxic Zinc oxide arises when welding galvanized steel sheets. For this reason, ensure that the working environment is well ventilated and there are suitable exhaust extraction systems to remove welding smoke, e.g. -V.A.G 1586 A-.

Spot welding only results in the zinc layer burning off slightly in the centre of the welding point and the protective zinc ring around the welding point, which arises at the same time, protects against corrosion. For this reason, this method is preferred to insert gas seam welding.

2.2.1 Inert gas seam welding of galvanized panels

Observe the following instructions to produce good repair weld joints:

- ◆ The current intensity at the welding transformer must be increased.

- ◆ At the same time, the wire feeder needs to be readjusted since just increasing the voltage only produces a larger light arc (less penetration, porous seam structure).
- ◆ Use cylindrical instead of conical gas nozzles (spatters on overly-narrow gas nozzles lead to pore formation).
- ◆ Guide the burner approx. 12 mm above the welding material in a neutral angle position to 10°.
- ◆ For MAG/MIG welding work, use mixed gas/argon as inert gas.

2.2.2 Spot welding of galvanized panels

Note the following points when spot welding galvanized panels:

Welding transformer

- ◆ Increase the welding current by 10 to 30 %.

It is better to extend the welding time when using welding transformers with “weld time regulation”.

- Weld time extension for these panel thicknesses (guidelines):
- 0.7 mm - min. 7 periods
- 0.8 mm - min. 9 periods
- 1.0 mm - min. 11 periods

The correct weld time is chosen when the welding points can be set without splatters.

Welding tongs

- ◆ Use hard-copper electrodes (copper-chrome-Zirconium alloy) with high heat resistance (>400 °C).
- ◆ Frequently clean the hard copper electrodes and rework to Ø 4 mm.
- ◆ Increase the electrode forming force.

Peel test

The best welding results can be obtained by welding sample panels with a subsequent peel test.

The narrow welded test strip is rolled off/torn off with a force from the second panel strip acting vertically on the surface of the panel.

Welding points of perfect quality do not tear in the tangential plane but are “peeled off”.

2.3 Removing residues

It is possible to cut the roughly damaged body part near to the spot welds using the body saw e.g. -V.A.G 1523 A- or the electrical cutting tool e.g. -V.A.G. 1561/A-. In this case, most spot-weld seams can be milled out with e.g. -V.A.G 1731-.

An angle grinder can also be used to separate the spot-weld seams that cannot be drilled out with the spot-weld drill.

2.4 New parts

To reduce the number of original parts, they are often only supplied in the “basic version”. In these cases, we recommended making “templates” from the damaged parts.

When fitting the template and pre-marking the holes before painting a new part, you must take into account the thickness of the material of the “template”.



- Cut out the hole with the body saw, e.g. -V.A.G 1523- .
- Clear sharp edge from the cut and apply corrosion protection
⇒ ["11 Corrosion prevention", page 46](#) .

Check new original parts, such as doors, flaps and wings, before handing over to the paintshop to see if they have been damaged during transport. If damage occurs during transport or an accident before installation, double coating is not possible.

2.5 Foam moulds

The foam moulds are fitted during the manufacturing of the body structure and expand in volume after the primer is applied in the drying chamber of the paint shop at approx. 180 °C.

Proceed in the following manner when using moulded foam parts:

- ◆ Remove any foam residue from the vehicle.
- ◆ Prepare the varnish according to the repair booklet chapter on varnish.

Preconditions

Before fitting the moulded foam part, prepare the panel to be replaced and make it ready for fitting, e.g. by cutting it to the required size, adjusting it and by taking the necessary measures to ensure anti-corrosion protection.

Replace the moulded foam part

- Remove residual foam from the vehicle.
- Use the original moulded foam part or cut the universal shield - 000 864 663- to size.
- Fit the sealing cord - AKD 497 010 04 R10- all around the moulded foam part or foam up the foam part with the 2K filling foam - D 506 KD1 A3- .
- Fix new part in place; apply gentle pressure to new part in the area of the moulded foam part until it abuts and weld in.

The filling foam hardens within 25 minutes.

Do not apply a protective gas seam up to 40 mm from the moulded foam parts (both sides).

- After painting the vehicle, preserve the cavities in the repair area.

2.6 Original welding

"Original welding" is the welding joint which was used when manufacturing the vehicle.

Where possible, these welding joints must be restored as part of a bodyshell repair.

In case of repair, you must not use fewer welding points than in series production; the same welding material must also be used.

After repair, apply precision seal.

2.7 Diagnosis of accident vehicles

When repairing vehicles involved in an accident, sometimes damage is not found on the chassis or the unit mounting as they can lead to major consequential damage later on under certain circumstances. In the event of accidents which indicate the vehicle was subject to high stresses, particular attention must be paid to the following parts - irrespective of the axle alignment which must be carried out anyway:



- ◆ If damage and/or distortion is suspected, the vehicle will need to be inspected on the frame alignment bench, and aligned if necessary.
- ◆ Check the steering and the steering linkage for perfect functioning across the entire angle. Perform a visual examination for bends or cracks.
- ◆ Check the suspension, all chassis parts such as arms, suspension struts, knuckles, anti-roll bars, assembly carriers, axle beams and their holding down springs for bends or cracks.
- ◆ Check alloys, tyres for damage, run-out and out of balance. Check tyres for cuts in the profile and on the flanks, check the tyre pressure.
- ◆ Check suspensions for engine, gearbox, axles and exhaust system for damage.
- ◆ By performing a suitable test drive after carrying out repairs means you can be sure the vehicle is roadworthy and can be handed back to the customer without any concerns.

2.8 Finishing work on the body

- If »rough filling« is needed, stop up the repair spot with putty ⇒ ["11.2 Body long-term protection if filling is needed", page 46](#) .
- Prepare the flattened and, where necessary, »roughly filled« surface using sandpaper with grain size P 80 to P 180 for subsequent corrosion treatment.
- Treat the repair spot against corrosion ⇒ ["11.1 Long-term body protection", page 46](#) .

This preliminary work is part of the work done by the body panel worker and is included in the time spent for the repair.

2.9 Repairing higher-strength body panels

The higher-strength panel is visually a normal panel which has a higher than normal yield strength than the normal body panel. This means that the indentation in the higher-strength sheet is not as deep as in the normal body panel with the same force acting on the panel.

Protected by copyright. Copying for private or commercial purposes, in part or in whole, is not permitted unless authorised by ŠKODA AUTO A. S. ŠKODA AUTO A. S. does not guarantee or accept any liability with respect to the correctness of information in this document. Copyright by ŠKODA AUTO A. S.

Buckling out

The usual tools are used to buckle out. A greater spring recoil force arises as a result of the larger dent resistance which means a greater force is needed. When kinks are deformed back, material fractures may result.

Alignment

The larger spring recoil force in the higher-strength panel means a greater overextension is required before it remains in the required position. Due to the higher force application, normal panels which are welded with a higher-strength panel are also subjected to greater strain. To prevent the normal panel from given away or tearing, additional anchors must be provided.



Note

- ◆ *If a higher -strength panel is overextended too strongly, it will suddenly jump to a larger length than desired!!!*
- ◆ *For safety reasons, do not heat higher-strength body panels when reverse forming in the same way that doing so with a normal body panel is also prohibited!*



Painting

When a higher-strength panel is warmed too quickly by drying radiation waves, it will expand. However, if the panel is firmly connected with the trim panels underneath it by welding points or bonding, dents arise at this points which continue to remain visible after the panel has cooled down. For this reason, heat radiators must only be brought slowly to max. heating level. Drying in the drying booth can proceed without risk.

2.10 High-strength/ultra-strength, warm-formed body panels



Note

Repairs must only be carried out in accordance with the instructions of the manufacturer according to the relevant Workshop Manual. High-strength and hot-formed steels may only be repaired with modern inverter technology, otherwise the optimum occupant protection following the repair does not exist. Panels made of tempered mould steel must be used in areas that are exposed to extreme strain. These panels offer significantly greater strength than conventional higher-strength panels at a lower weight.

Do not repair parts from high/ultra-strength, hot-formed steel based on the extent of the damage. Completely cut out the damaged component and replace it by a new original part unless another repair procedure is described in the Workshop Manual.

RP spot-welding of ultra-strength, hot-formed body panels



Note

- ◆ *High and ultra high-strength and hot-formed steels are used in the area of the A, B and C-pillars. The welding bars in this area are approx. 13 mm wide.*
- ◆ *If the welding points are positioned at the edge of the hot-formed panels, the structure of the plates is changed through the increase in temperature in such a way that it has a negative effect on the crash behaviour.*
- Therefore the welding points must be positioned as far as possible to the inside.

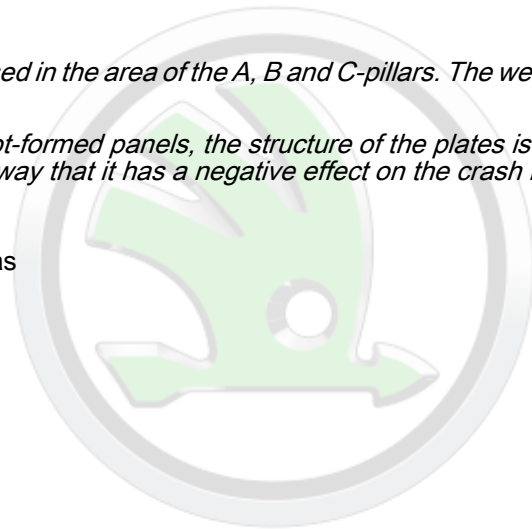

ŠKODA

Protected by copyright. Copying for private or commercial purposes, in part or in whole, is not permitted unless authorised by ŠKODA AUTO A. S. ŠKODA AUTO A. S. does not guarantee or accept any liability with respect to the correctness of information in this document. Copyright by ŠKODA AUTO A. S.

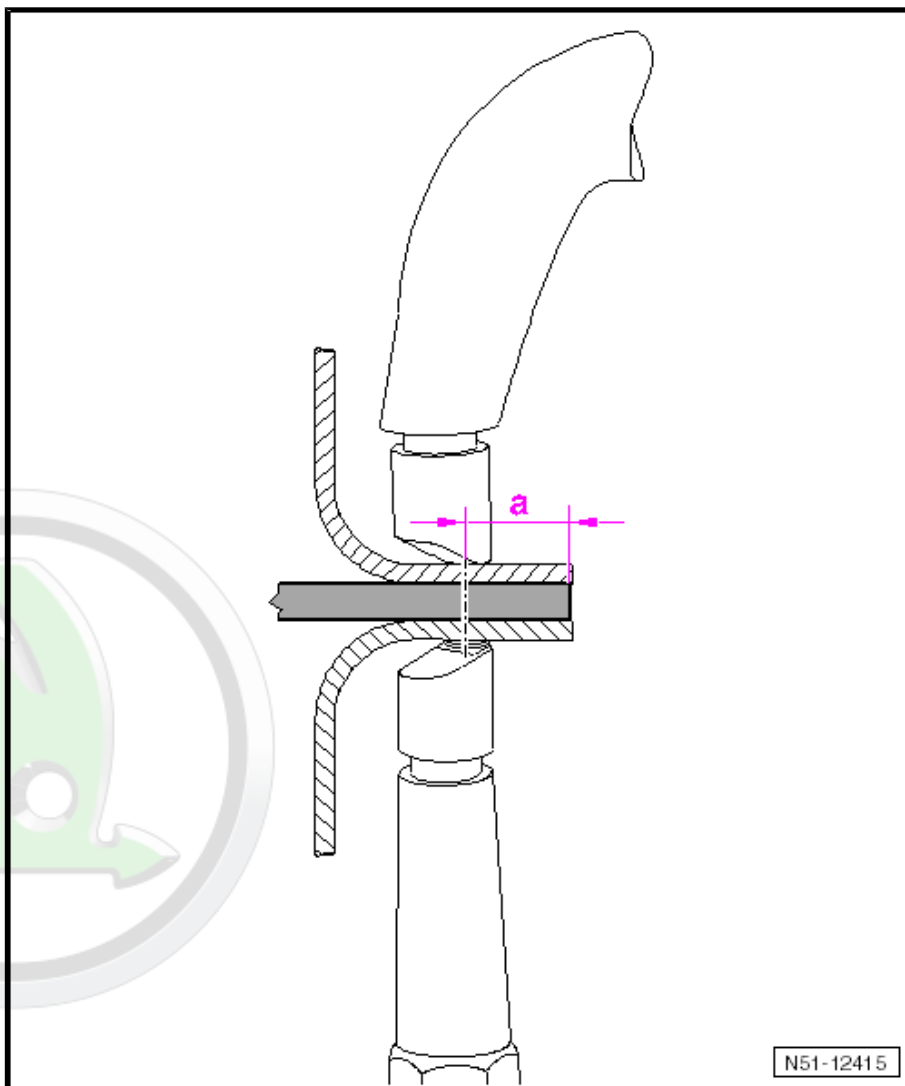

The dimension -a- of 8 mm can be obtained if the welding caps are chamfered.

Protected by copyright. Copying for private or commercial purposes, in part or in whole, is not permitted without the prior written authorisation of ŠKODA AUTO A. S. ŠKODA does not guarantee or accept any liability with respect to the correctness of information in this document. Copyright by ŠKODA AUTO A. S.

2.11 Body Work - Glued joints

To increase the stiffness and strength of bodysHELLS, an increasingly greater number of spot welding joints and glued joints are created at the factory.

High-strength glued joints

With glued joints, the panels are only joined with glue.

The clearance between the high-strength adhesive surfaces should not be less than 2 mm or greater than 4 mm. The adhesive surfaces may need to be aligned.

The glued joints are re-established with the materials indicated in the Workshop Manual/in the spare part programme.

Spot welding glued joints

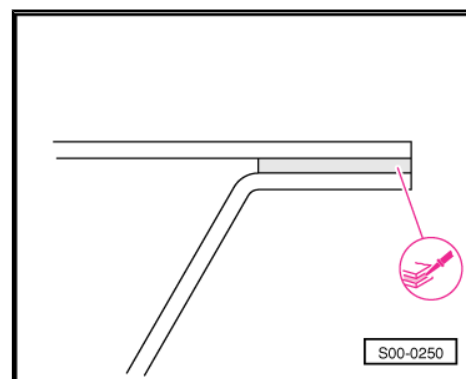



For the spot welding joints, an electrically conductive adhesive is located between the panels allowing you to weld through easily.

The clearance between the spot weld adhesive surfaces should not be more than 1 mm. The adhesive surfaces may need to be aligned.

With spot welding adhesion, the welding current must not be increased. The pre-pressing time must be extended due to displacement of the adhesive, approx. 30-50 periods. The resulting gases must be suctioned off.

Repairing glued joints

As a replacement for the spot welding adhesive, the adhesive - DA 001 730 A2- must be used together with the compressed air adhesive gun e.g. -V.A.G 2005B-.

The procedures vary according to the type of welding involved as follows:

Spot welding and gluing

When spot welding and gluing, the full number of welding points and glue joints are replaced.

When there are issues with the welding, e.g. only the outer panel is replaced with a 3-layer panel connection, the repair welding points are to be set to the old welding points.

Inert gas seam welding and gluing (if spot welding is not possible)

If it is not possible to access an adhesive area with a spot welder, the area will be welded with inert gas shielded plug weld.

In this case, adhesive is not used in order to achieve the required welding quality.

Preparing glued joints

The panels to be welded must be adjusted before applying the adhesive.

The adhesive surfaces in the welding area must be free of primer and residual adhesive, dust and grease.

Applying zinc spray to the adhesive area which normally applies, is not required.

As a result of the displacement of adhesive during spot welding, the blank spot-welded flange is moistened with adhesive to ensure anti-corrosion protection.

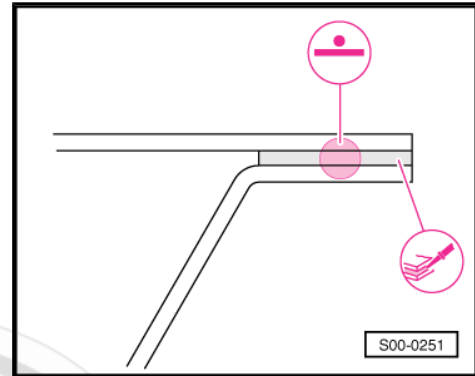

2.12 Removing underbody protection and sealing seams

Removal of underbody protection and sealing seams is carried out e.g. with an induction heater or mechanically.



Note

Wear protective spectacles and protective gloves. The pieces of wire which may fly off are very sharp.

Another option lies in heating the underbody protection or sealing seam with a hot air blower (max. 420 °C) and to remove the underbody protection which becomes softer as a result or the sealing seam with a scraper. We particularly recommend this procedure for poorly-accessible working areas.



WARNING

The resulting vapours are poisonous and must be suctioned off using suitable exhaust extraction systems, e.g. -V.A.G 1586 A-.

Remove paint and priming with paint stripper.



ŠKODA

Protected by copyright. Copying for private or commercial purposes, in part or in whole, is not permitted unless authorised by ŠKODA AUTO A. S. ŠKODA AUTO A. S. does not guarantee or accept any liability with respect to the correctness of information in this document. Copyright by ŠKODA AUTO A. S.



3 Explanation of symbols

⇒ ["3.1 Symbols, structure", page 14](#)

⇒ ["3.2 Symbols, preparation", page 15](#)

⇒ ["3.3 Symbols, welding", page 16](#)

⇒ ["3.4 Symbols, riveting", page 17](#)

⇒ ["3.5 Symbols, corrosion protection", page 18](#)

3.1 Symbols, structure

- 1 - Sanding
- 2 - Bore
- 3 - Milling (laser weld seam)
- 4 - BYR milling
- 5 - Separation cut
- 6 - Hole with support
- 7 - Cutting

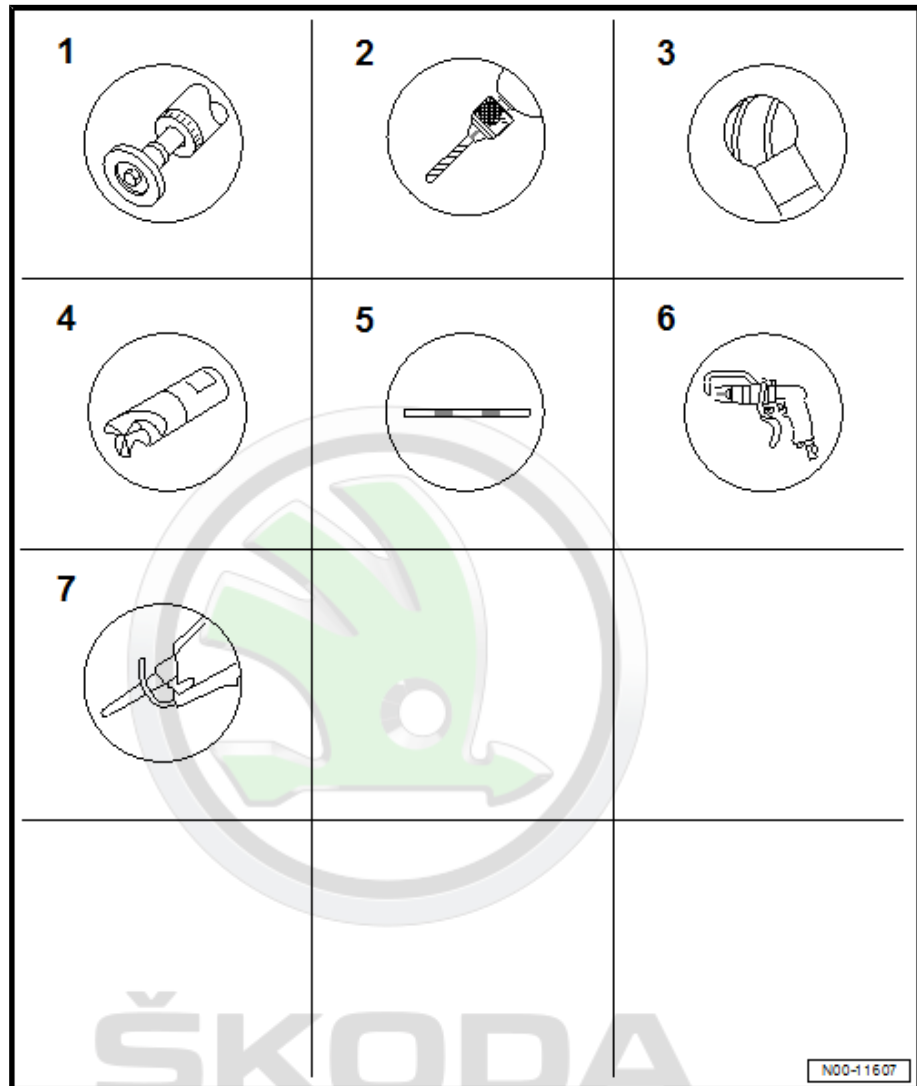

Protected by copyright. Copying for private or commercial purposes, in part or in whole, is not permitted unless authorised by ŠKODA AUTO A. S. ŠKODA AUTO A. S. does not guarantee or accept any liability with respect to the correctness of information in this document. Copyright by ŠKODA AUTO A. S.

3.2 Symbols, preparation

- 1 - Tensioning
- 2 - Shoulder
- 3 - Removing paint (areas that are difficult to access)
- 4 - Sanding by hand
- 5 - Gluing
- 6 - Create holes with punch pliers
- 7 - Crimping

1	2	3
4	5	6
7		
		N00-11610

Protected by copyright. Copying for private or commercial purposes, in part or in whole, is not permitted unless authorised by ŠKODA AUTO A. S. ŠKODA AUTO A. S. does not guarantee or accept any liability with respect to the correctness of information in this document. Copyright by ŠKODA AUTO A. S.



3.3 Symbols, welding

1 - Gas arc quilting seam (where necessary, must be ground off flush to the body-shell contour)

The welding seam comprises many separate welding points arranged in series. The lower amount of heat generated is an advantage over the gas arc full seam.

2 - Gas arc perforation

One of the panels to be joined is given \varnothing 7 mm holes (bored or cut out with punch pliers) at a distance of 20-30 mm in the area of the connection points in which a good gas arc hole is set.

3 - Gas arc full seam (where necessary, must be ground off flush to the bodyshell contour)

The welding seam is executed without interruption where possible.

4 - Gas arc full seam, interrupted (where necessary, must be ground off flush to the body-shell contour)

The welding seam comprises gas arc full seams arranged in series at approx. 20 mm apart, separated by interstices of the same length.

5 - Brazing

6 - MIG brazing

7 - Spot welding (RP)

8 - Spot welding seem (one layer)

9 - Spot welding seam (two layer)

10 - Spot welding seam (two layer offset)

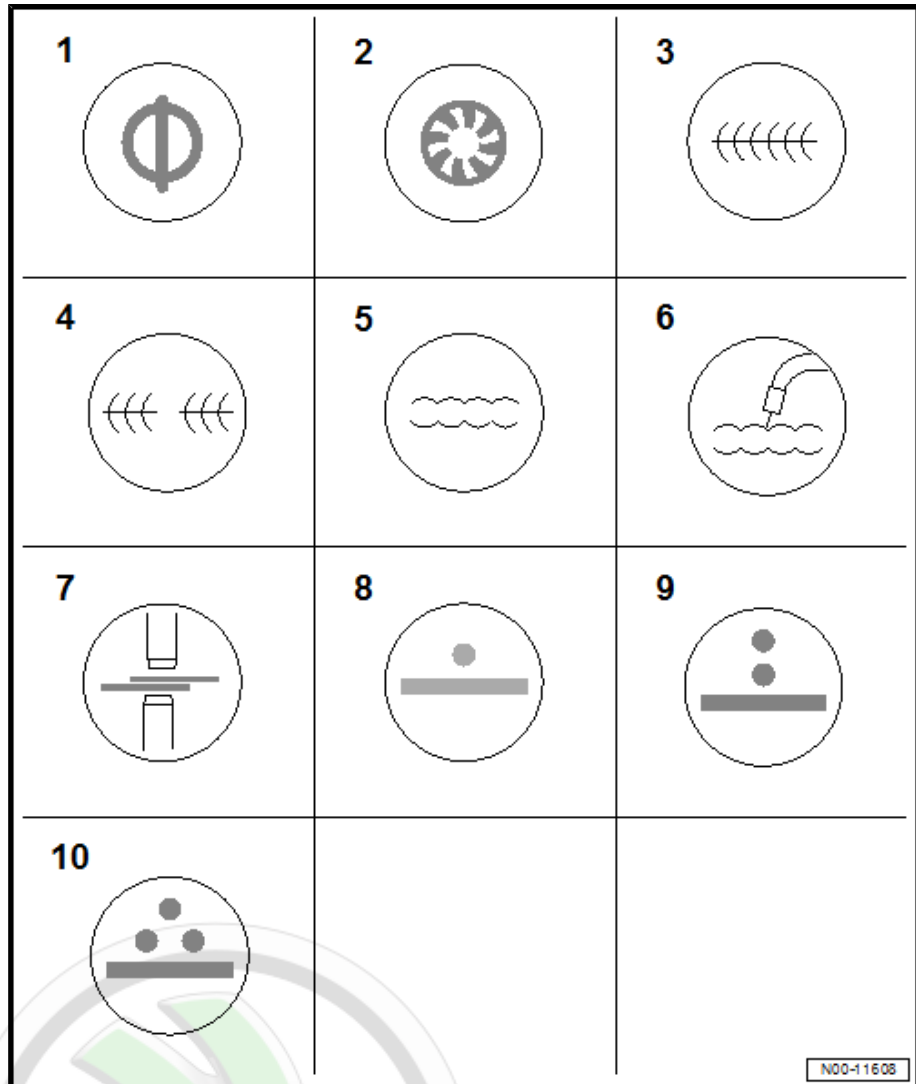

ŠKODA

Protected by copyright. Copying for private or commercial purposes, in part or in whole, is not permitted unless authorised by ŠKODA AUTO A. S. ŠKODA AUTO A. S. does not guarantee or accept any liability with respect to the correctness of information in this document. Copyright by ŠKODA AUTO A. S.



3.4 Symbols, riveting

- 1 - Solid rivet
- 2 - Riveted nuts
- 3 - Riveting tongs
- 4 - Pop rivet

1 	2 	3
4 		

N00-11609





Protected by copyright. Copying for private or commercial purposes, in part or in whole, is not permitted unless authorised by ŠKODA AUTO A. S. ŠKODA AUTO A. S. does not guarantee or accept any liability with respect to the correctness of information in this document. Copyright by ŠKODA AUTO A. S.



3.5 Symbols, corrosion protection

1 - Cavity preservation

2 - Seal

1 	2 	
		N00-11611

ŠKODA

Protected by copyright. Copying for private or commercial purposes, in part or in whole, is not permitted unless authorised by ŠKODA AUTO A. S. ŠKODA AUTO A. S. does not guarantee or accept any liability with respect to the correctness of information in this document. Copyright by ŠKODA AUTO A. S.



4 Vehicle body structure features

⇒ ["4.1 Multimedia mix", page 19](#)

4.1 Multimedia mix

In addition to the classic clean steel body, more and more mixed body superstructures are used. This means that various materials are used in combination with one another.

Common materials in modern vehicle bodies:

- ◆ Steel (different strengths)
- ◆ Aluminium
- ◆ Magnesium
- ◆ Plastics
- ◆ Fibre composite plastics
- ◆ Carbon fibre materials

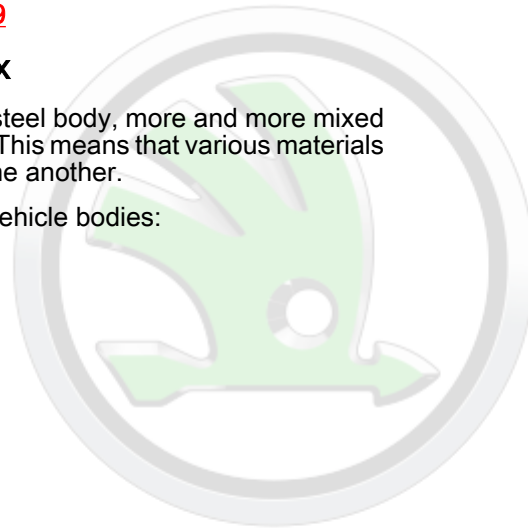

ŠKODA

Protected by copyright. Copying for private or commercial purposes, in part or in whole, is not permitted unless authorised by ŠKODA AUTO A. S. ŠKODA AUTO A. S. does not guarantee or accept any liability with respect to the correctness of information in this document. Copyright by ŠKODA AUTO A. S.



5 Damage assessment

⇒ [“5.1 General points”, page 20](#)

⇒ [“5.2 Check weld seams and body connections”, page 20](#)

⇒ [“5.3 Force reduction during impact”, page 20](#)

⇒ [“5.4 Measuring methods / damage diagnostics”, page 23](#)

⇒ [“5.5 Overview of the materials used”, page 23](#)

⇒ [“5.6 Passive safety”, page 25](#)

5.1 General points

When repairing vehicles involved in an accident, damage on the chassis or the unit mounting cannot be overlooked; as they can lead to major consequential damage later on under certain circumstances. In the event of accidents which indicate the vehicle was subject to high stresses, particular attention must be paid to the following parts - irrespective of the axle alignment which must be carried out anyway:

- ◆ Check steering and steering linkage for perfect functioning across the angle. Carry out a visual check for bends or cracks.
- ◆ Check suspension, all chassis parts such as arms, suspension struts, knuckles, anti-roll bars, assembly carriers, axle beams and their holding down springs for bends or cracks
- ◆ Examine alloys, tyres for damage, run-out and imbalance. Check tyres for cuts in the profile and on the flanks, check the tyre pressure.
- ◆ Examine suspensions for engine, gearbox, axles and exhaust system for damage.
- ◆ By performing a suitable test drive after carrying out repairs means you can be sure the vehicle is roadworthy and can be handed back to the customer without any concerns.

5.2 Check weld seams and body connections

The method of color penetration is suitable for testing surface cracks. For this purpose, the approved materials must be used.



Note

Do not clean the area with a brush before the test, the cracks could become soiled.

5.3 Force reduction during impact

ŠKODA

Protected by copyright. Copying for private or commercial purposes, in part or in whole, is not permitted unless authorised by ŠKODA AUTO A. S. ŠKODA AUTO A. S. does not guarantee or accept any liability with respect to the correctness of information in this document. Copyright by ŠKODA AUTO A. S.

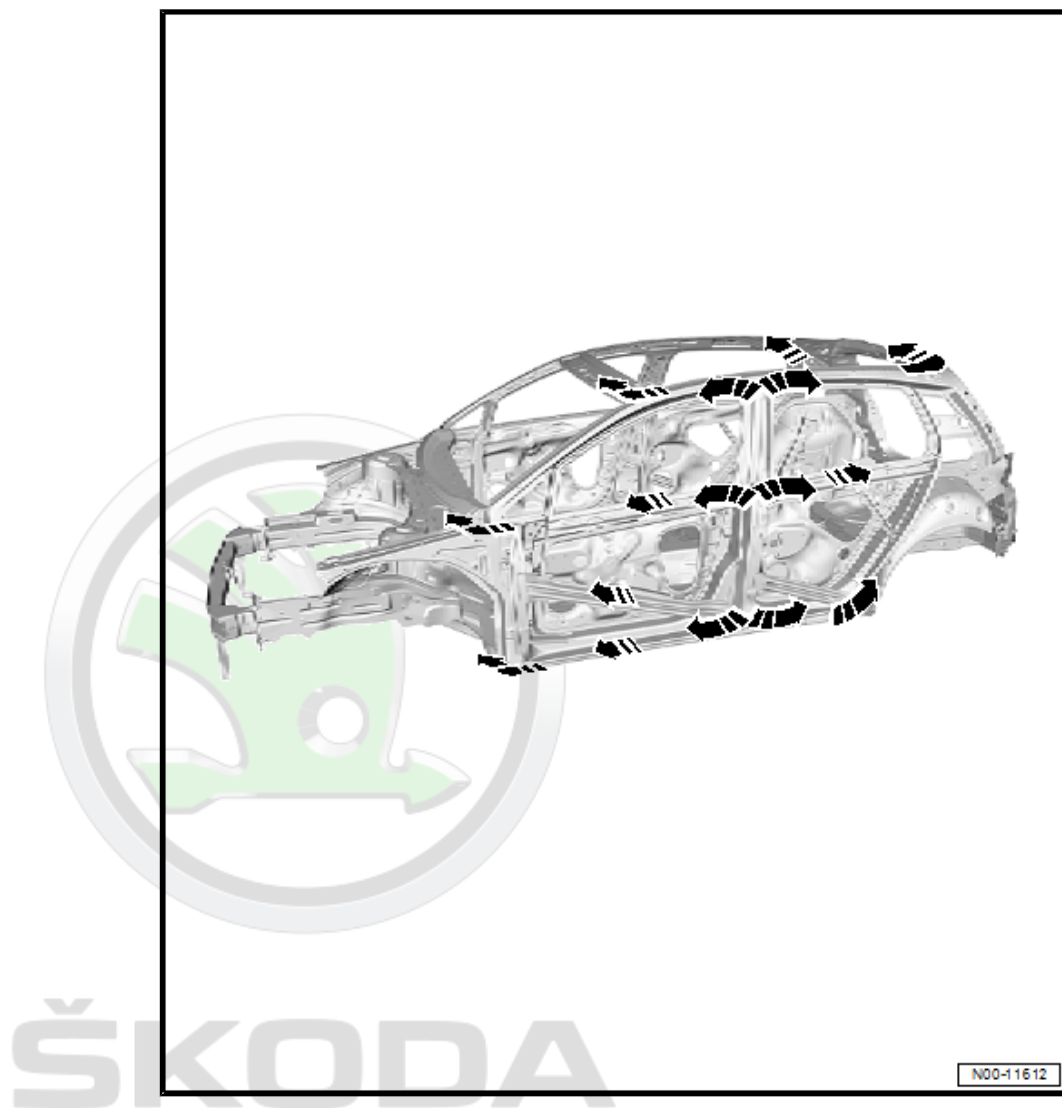

Protected by copyright. Copying for private or commercial purposes, in part or in whole, is not permitted without the prior written consent of ŠKODA AUTO A. S. ŠKODA AUTO A. S. does not warrant or accept any liability for the accuracy of the information provided.

The illustration above explains how the energy is conducted around the vehicle cabin during the side impact. In the case of damage assessment, particular attention should therefore be paid to door side impact, as well as to connecting the A and B pillar to the side rail and the roof frame.

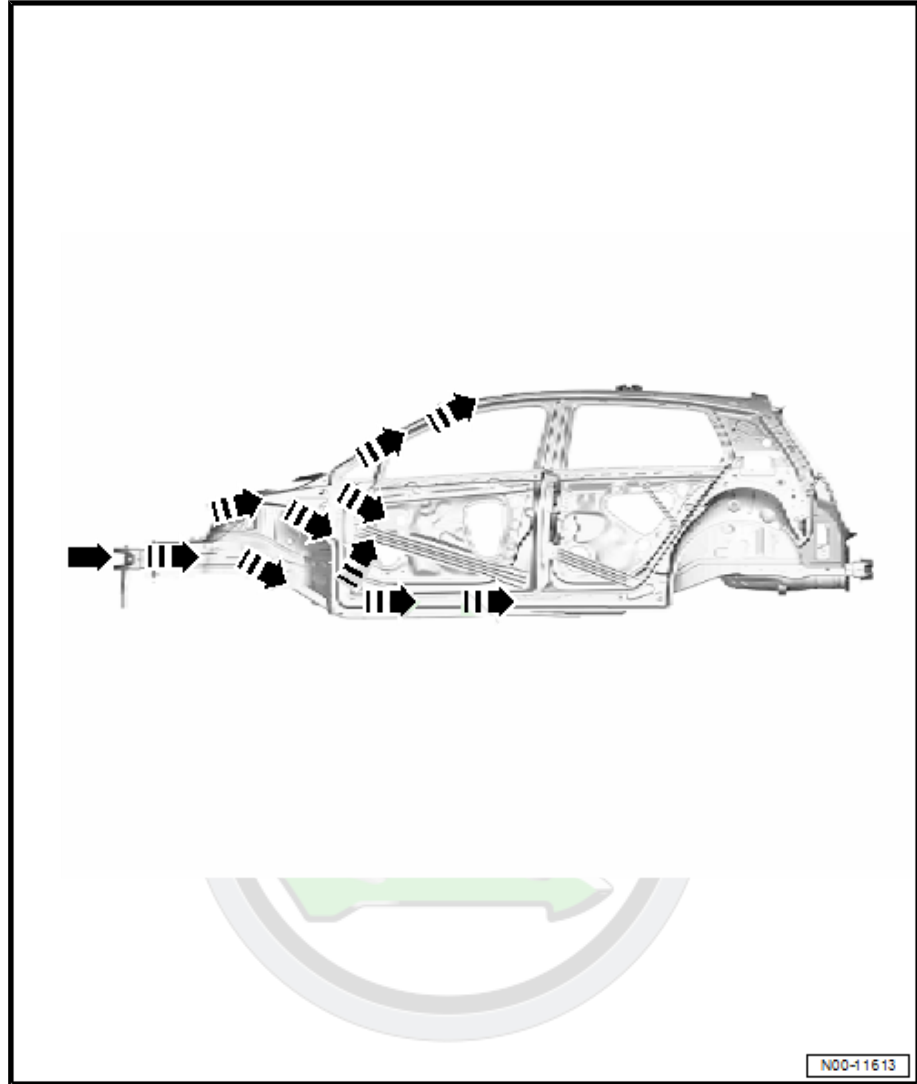

The goal of the body design is that as much energy as possible is dissipated in the area of the front bodywork.

If the structural damage in the front part of the vehicle is significantly damaged, the transition area of the A-pillar to the roof frame or lower part must also be taken into account in the event of a damage assessment.

or commercial purposes, in part or in whole, is not permitted
S. ŠKODA AUTO A. S. does not guarantee or accept any liability
with respect to the correctness of information in this document. Copyright by ŠKODA AUTO A. S.

Due to the structure, the entire outer mantle should also be inspected because elastic deformations of the high-strength structure can cause plastic deformations in the outer mantle.

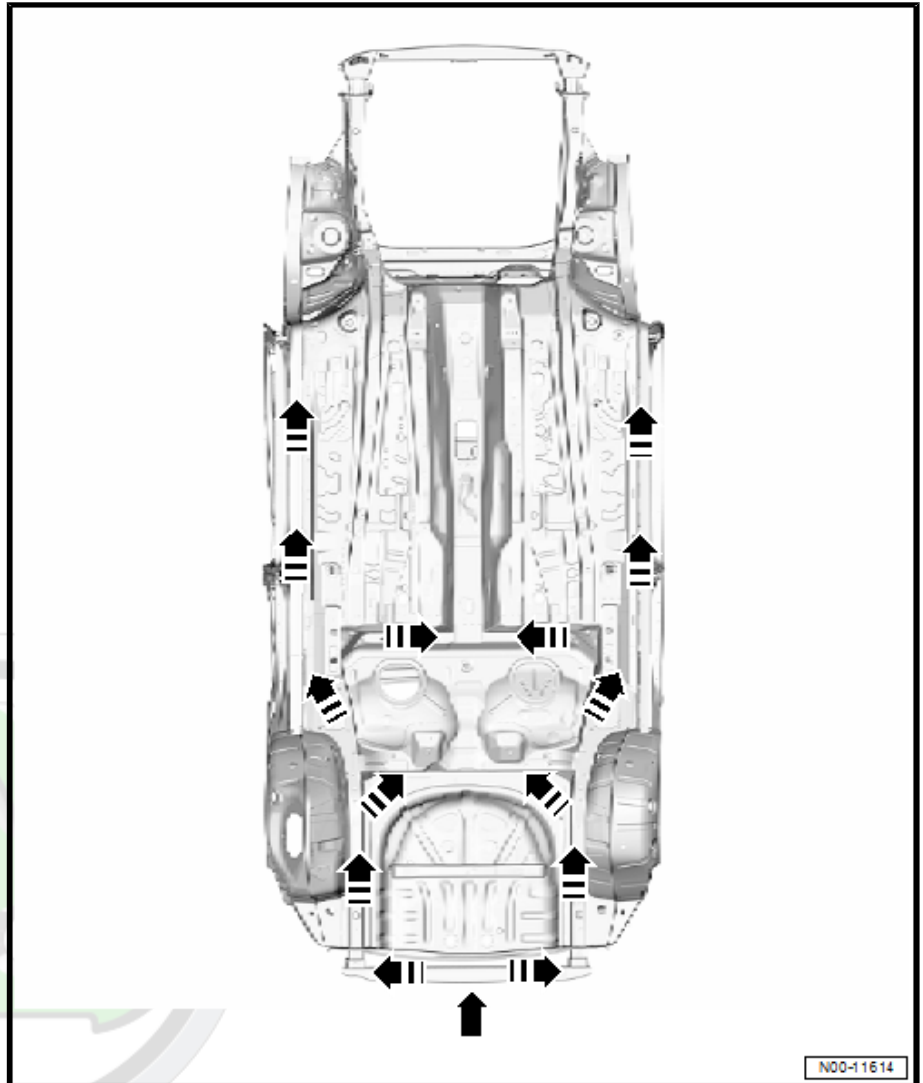

In the event of a damage assessment at the rear, one should pay particular attention to the sheet metal deformation in the area of the boot floor. Due to the suspension effect of the applied materials, damage can occur here, although longitudinal beams have no dimensional deviation.

5.4 Measuring methods / damage diagnostics

Protected by copyright. Copying for private or commercial purposes, in part or in whole, is not permitted unless authorised by ŠKODA AUTO A. S. ŠKODA AUTO A. S. does not guarantee or accept any liability with respect to the content of this document.

- ◆ You will find information on approved measuring instruments
⇒ ŠKODA AUTO a. s. workshop standards .
- ◆ Information on body dimensions as well as clearance dimensions can be found in the vehicle-specific repair instructions.

5.5 Overview of the materials used

⇒ [“5.5.1 Special features of deep drawn steels”, page 23](#)

⇒ [“5.5.2 Special features of high-strength and ultra-strength steels”, page 24](#)

⇒ [“5.5.3 Connection elements”, page 25](#)

5.5.1 Special features of deep drawn steels

The car bodies and the body platform are manufactured from cold-formed deep-drawing panels in series production. For this



reason, reverse deformation is carried out in the same way. If the damage circumference does not allow deformation, the damaged part should only be cut out after the bearing surfaces have been balanced.

5.5.2 Special features of high-strength and ultra-strength steels

High-strength plates are increasingly used in our vehicles. The areas of use of these plates are shown in a image in the repair manual → Bodywork repair; 00 Specifications; Galvanised body parts, high / high strength and thermoformed body panels,

What is higher-strength sheet metal?

A normal panel visually which has a higher that normal yield strength than the normal body panel. This means that the indentation in the higher-strength sheet is not as deep as in the standard body panel with the same force acting on the panel.

What must be taken into account during the bulking process?

The usual tools are used to buckle out. A greater spring recoil force arises as a result of the larger dent resistance which means a greater force is needed. When kinks are deformed back, material fractures may result.

What must be done when straightening with the straightening bench or hydraulic press?

The larger spring recoil force in the higher-strength panel means a greater overextension is required before it remains in the required position. Due to the higher force application, normal panels which are welded with a higher-strength panel are also subjected to greater strain. To prevent the normal panel from given away or tearing, additional anchors must be provided.



WARNING

- ◆ *If a higher -strength panel is overextended too strongly, it will suddenly jump to a larger length than desired!!!*
- ◆ *For safety reasons, do not heat higher-strength body panels when reverse forming in the same way that doing so with a standard body panel is also prohibited!*
- ◆ *Welding high-strength steels is permitted according to the repair guidelines with the specified cutting sections and welding methods.*

use of this information for commercial purposes, in part or in whole, is not permitted unless authorised by ŠKODA AUTO A. S. ŠKODA AUTO A. S. does not guarantee or accept any liability with respect to the correctness of information in this document. Copyright by ŠKODA AUTO A. S.

What are the most advanced hot-formed steel sheets?

Steel sheets which, as the name suggests, are formed in hot conditions at temperatures between 900 ° C and 950 ° C. The steel sheets obtain their high strength, via a specific cooling process in the moulding tool. They are mould-hardened. Using ultra-strength hot-formed steel plates reduced the weight of the body without any loss in strength. For vehicles with the ultra-strength hot-formed steels, only spot welders with inverter technology (see operating equipment and special tools catalogue) may be used.

Stretching limits of the sheet steel used:

Identification	Stretching limits
Low-strength steels - common deep-drawing steels	<300 MPa (N / mm ²)
High strength HSS steels	270 - 700 MPa (N/mm ²)
High strength micro-alloyed HSLA steels	350 - 730 MPa (N/mm ²)



Identification	Stretching limits
Ultra high-strength UHSS steels	450 - 1180 MPa (N/mm ²)
Hot-formed high-strength MS steels	1200 - 2000 MPa (N/mm ²)

5.5.3 Connection elements

Using of unsuitable connection elements (screws, nuts, washers, etc.) can cause contacts to become corroded. This is why only connection elements with a special surface coatings are fitted. The rubber or plastic parts and the adhesives are also made from electrically non-conductive materials. If there is a doubt about re-usability of parts, new parts ETKA - Electronic Catalogue of Original Parts must generally be installed.



Note

- ◆ *Only use genuine parts! They are tested and can be used on aluminium.*
- ◆ *Accessories must be approved by ŠKODA AUTO a. s!*
- ◆ *When using materials which are not approved, damage by contact corrosion is not covered by the warranty!*

5.6 Passive safety

- ◆ Child restraint systems (safety belt systems)
- ◆ Safety instructions for seatbelt tensioners
- ◆ Working on the vehicle with seatbelt tensioners
- ◆ Dispose of pyrotechnic components which have not been triggered
- ◆ Child restraint systems (airbag systems)
- ◆ Special features when working with seats with side airbag
- ◆ Disposal methods

Information can be found in vehicle-specific repair instructions ⇒ Body - interior assembly work; Rep. gr. 69 ; Occupant protection; seat belts

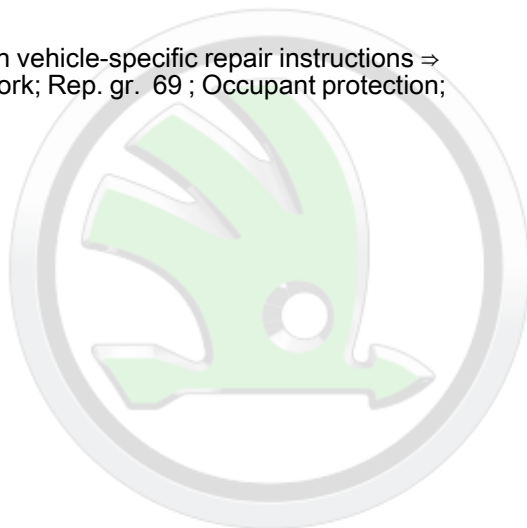

ŠKODA



6 Methods of thermal connection

⇒ [“6.1 Methods of thermal connection”, page 26](#)

⇒ [“6.2 Spot welding \(RP\)”, page 26](#)

⇒ [“6.3 Hole seams - shielding gas”, page 27](#)

⇒ [“6.4 Seal with SG full seam \(shielding gas\) and quilting seam”, page 28](#)

⇒ [“6.5 MIG welding”, page 29](#)

⇒ [“6.6 Laser welding”, page 30](#)

⇒ [“6.7 Laser soldering”, page 30](#)

⇒ [“6.8 Replacement gap method during repair \(steel\)”, page 31](#)



6.1 Methods of thermal connection

The following chapter presents thermal connection methods that are currently used in body repairs.

6.2 Spot welding (RP)

The basic principle of the most faithful manufacture of the original welded joint can be found in repair work using welding.

This assumes that:

- ◆ Welded sheets cover each other.
- ◆ The welding point is accessible on both sides for electrodes.
- ◆ Device output for spot welding (RP) means that it is possible to manufacture the welding point at the factory.

Access to the welding points is different for service work on the body. Therefore, the complete set of the most versatile designs of electrodes for spot welding (RP) must be available.

Spot welding of galvanized panels

Note the following points when spot welding galvanized panels:

- ◆ The flanges to be joined must lie flat. The flanges may be clamped with pliers.
- ◆ This is particularly important for high-strength sheet metal, since otherwise the electrode force is not sufficient.
- ◆ Do not use the welding tongs directly next to the clamping jaws, since otherwise a large part of the welding current flows off by shunt.
- ◆ If you have small distances between points, join points in a row or join every 3rd point for fixing, and then separate them. This reduces the influence of the shunt.
- ◆ Observe the Owner's Manual and the installation instructions for the appliance manufacturer.

Copying for private or commercial purposes, in part or in whole, is not permitted without the prior written authorisation of ŠKODA AUTO A. S. ŠKODA AUTO A. S. does not guarantee or accept any liability with respect to the correctness of information in this document. Copyright by ŠKODA AUTO A. S.

Gauges, instruments

Only approved instruments according to ⇒ ŠKODA AUTO a. s. workshop standards may be used.

Peel test

- For the required displacement average of sheet metal RP welding, determine the setting parameters according to the manufacturer's specifications and test them with test plates.
- Check all point connections 100% with a chisel.

During this test, welding points of perfect quality do not tear in the tangential plane but are "peeled off".

- Cut out the knob diameter according to the following formula and check on the test plates before the start of the repair.

Square root z $T1 \cdot 3.5 \cdot 1.15$



Note

T1 is the thinnest sheet metal of a sheet metal pair, For example, a 1.5 mm and 0.8 mm sheet metal pairing. Calculation example: root of $0.8 \times 3.5 \times 1.15 = 3.6$ mm peel-off diameter. In this test, the narrow welded pro strip is unrolled, or unrolled with force acting perpendicular to the sheet metal surface.

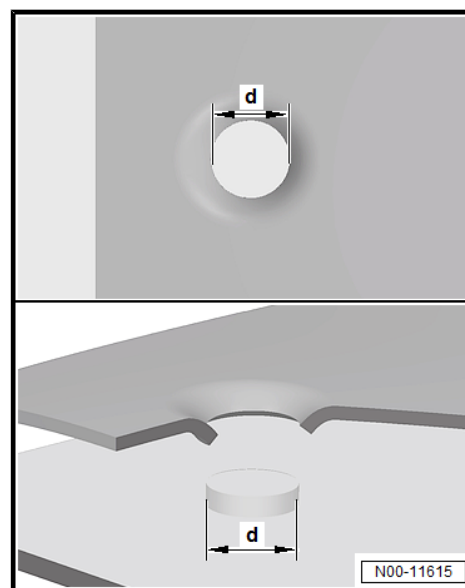

Gauges, instruments

Only approved instruments according to ⇒ ŠKODA AUTO a. s. workshop standards may be used.



WARNING

- ◆ **Welding and grinding must always be carried out with suction!**
- ◆ **Never weld and grind in a room at the same time!**
- ◆ **Thoroughly clean the working area as per dust accumulation!**
- ◆ **Dust particles must not be blown out with compressed air!**
- ◆ **Cleaning of the exhaust gas extraction system must be carried out at regular intervals!**
- ◆ **The respective UVV and BG regulations must also be observed.**

6.3 Hole seams - shielding gas

Point-hole seams (shielding gas) are usually used when standard resistance points can not be restored e.g. due to limited access.

Observe the vehicle-specific repair instructions.

Protected by copyright. Copying for private or commercial purposes, in part or in whole, is not permitted unless authorised by ŠKODA AUTO A. S. ŠKODA AUTO A. S. does not guarantee or accept any liability with respect to the correctness of information in this document. Copyright by ŠKODA AUTO A. S.



Fundamentals of hole spot welding (shielding gas)

- ◆ Detach the weld points with a milling cutter for weld points or grind them.
- ◆ Remove the damaged part, cut it off with a chisel, if required.
- ◆ Grind the overhangs.
- ◆ Adjust the new part.
- ◆ Drill the top plate for hole seam welding (in the repair guide thread, determine the vehicle-specific drilling averages).
- ◆ Clean the flanges and remove the corroded layer.
- ◆ Carry out hole seam welding from the centre to the outside.



Note

Rivets are also permitted in part. Follow the "Body Repair" repair booklet.

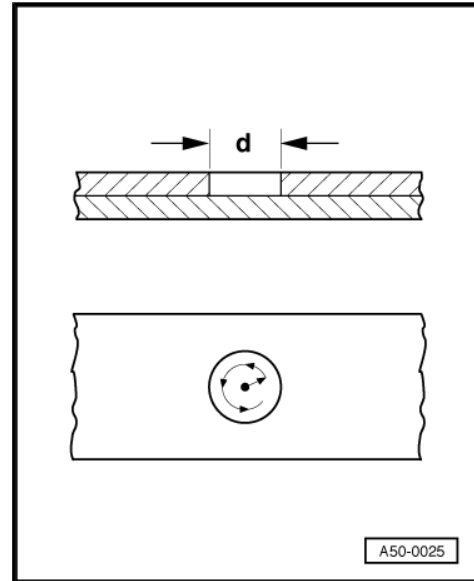

Gauges, instruments

Only approved instruments according to ⇒ ŠKODA AUTO a. s. workshop standards may be used.



WARNING

- ◆ ***Welding and grinding must always be carried out with suction!***
- ◆ ***Never weld and grind in a room at the same time!***
- ◆ ***Thoroughly clean the working area as per dust accumulation!***
- ◆ ***Dust particles must not be blown out with compressed air!***
- ◆ ***Cleaning of the exhaust gas extraction system must be carried out at regular intervals!***
- ◆ ***The respective UVV and BG regulations must also be observed!***

6.4 Seal with SG full seam (shielding gas) and quilting seam

Welding with SG full seam (shielding gas) or with quilting seam is mostly used for fitting dull or overlapping borders. Depending on very high temperatures during welding and the related modified properties of modern materials, the range of application for this bonding method is increasingly limited. Observe the vehicle-specific repair instructions.

Gauges, instruments

Only approved instruments according to ⇒ ŠKODA AUTO a. s. workshop standards may be used.

**WARNING**

- ◆ *Welding and grinding must always be carried out with suction!*
- ◆ *Never weld and grind in a room at the same time!*
- ◆ *Thoroughly clean the working area as per dust accumulation!*
- ◆ *Dust particles must not be blown out with compressed air!*
- ◆ *Cleaning of the exhaust gas extraction system must be carried out at regular intervals!*
- ◆ *The respective UVV and BG regulations must also be observed!*

6.5 MIG welding

MIG soldering is fundamentally different from stepped seam welding (shielding gas) or SG full seam due to the significantly lower temperatures that are required. The advantage of MIG soldering is a markedly reduced warping of the material in the components which have to be connected. Therefore, the connection method is also suitable for larger, flat components.

Further advantages are:

- ◆ Lower structural changes in components.
- ◆ Reduces the amount of corrosion protection that is standard.
- ◆ Preservation of the zinc layer on the components.

What is MIG soldering

- ◆ This is the brazing method, which is also called metal brazing under inert gas.
- ◆ The base material (bodywork sheet) is not fused, soldering is used to coat the edges and connect the components.
- ◆ MIG is an abbreviation of metal inert gas. Inert gases have no share of the processes between the electric arc and the weld.
- ◆ The inert gases used include argon or helium, mixed with carbon dioxide or oxygen.
- ◆ up to 450 ° C: soldering
- ◆ from 450 ° C: brazing

Gauges, instruments

Only approved instruments according to ⇒ ŠKODA AUTO a. s. workshop standards may be used.



ŠKODA

Protected by copyright. Copying for private or commercial purposes, in part or in whole, is not permitted unless authorised by ŠKODA AUTO A. S. ŠKODA AUTO A. S. does not guarantee or accept any liability with respect to the correctness of information in this document. Copyright by ŠKODA AUTO A. S.



WARNING

- ◆ *Welding and grinding must always be carried out with suction!*
- ◆ *Never weld and grind in a room at the same time!*
- ◆ *Thoroughly clean the working area as per dust accumulation!*
- ◆ *Dust particles must not be blown out with compressed air!*
- ◆ *Cleaning of the exhaust gas extraction system must be carried out at regular intervals!*
- ◆ *The respective UVV and BG regulations must also be observed!*

6.6 Laser welding



Note

This compounding method is used exclusively in production.

You can find information about the replacement method in the index in chapter [⇒ "6.8 Replacement gap method during repair \(steel\)", page 31](#).

Observe the vehicle-specific repair instructions.

During laser welding, a high-energy light beam is fed to the weld seam position using optical glasses or using optical fibres. During welding, the sheet metal is melted and the under-plate is melted, and the weld seam is fed out with and without additional material.

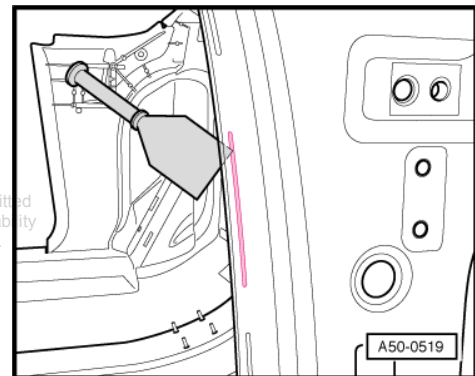

6.7 Laser soldering



Note

This compounding method is used exclusively in production.

You can find information about the replacement method in the index in chapter [⇒ "6.8 Replacement gap method during repair \(steel\)", page 31](#).

Observe the vehicle-specific repair instructions.

In laser welding, only supplementary material is used. The welded joint does not significantly differ from the MIG solder joint.

Only melting of the additional material is not carried out using an electric arc, but, as in the case of laser welding, using a concentrated beam of light. With laser technology, energy can accurately lead to the point. Unintended side effects such as heat deformations are slightly small.



6.8 Replacement gap method during repair (steel)

In production	For repair
Spot welding	Spot welding adhesives / MAG spot welding / MAG welding
MAG welding	MAG welding
MIG welding	MAG welding
Laser welding	MAG welding
Laser soldering	MIG brazing bonding MAG welding Observe the information in the repair booklet
Gluing	Bonding / MAG welding
Spot weld-bonding	Bonding with points / additional welding points / additional MAG welding
Blind rivets	Blind rivets Use only predefined blind rivets according to RLF. Commercial blind rivets generally do not have sufficient strength.

Protected by copyright. Copying for private or commercial purposes, in part or in whole, is not permitted unless authorised by ŠKODA AUTO A. S. ŠKODA AUTO A. S. does not guarantee or accept any liability with respect to the correctness of information in this document. Copyright by ŠKODA AUTO A. S.



7 Cold connection methods

⇒ [“7.1 Gluing”, page 32](#)

⇒ [“7.2 Rivet”, page 32](#)

⇒ [“7.3 Overview - Pairing riveting tools”, page 37](#)

⇒ [“7.4 FDS screws \(flow drill screws\)”, page 38](#)

⇒ [“7.5 Pressing through”, page 39](#)

7.1 Gluing

To increase the stiffness and strength of bodyshells, an increasingly greater number of spot welding joints and glued joints are created at the factory.

These compounds differ as follows:

- ◆ With glued joints, the panels are only joined with glue.
- ◆ When gluing with additional point or rivet connections, so-called hybrid bonding is used.



Note

The adhesive connection may only be re-established with materials specified in the repair guide thread or in the spare part program.

7.2 Rivet

⇒ [“7.2.1 Solid rivet”, page 32](#)

⇒ [“7.2.2 Pop rivet”, page 33](#)

⇒ [“7.2.3 Rivet faults”, page 34](#)



Note

For remarks on the special tools, test and measuring instruments and auxiliary equipment required, please refer to the vehicle-specific repair instructions or the → Škoda auto a.s. workshop standards.

7.2.1 Solid rivet

Open the rivet

- If necessary, Carry out separation cuts.
- Squeeze the locking head and the rivet with a rivet tool.
- Remove the damaged part, cut it off with a chisel, if required.

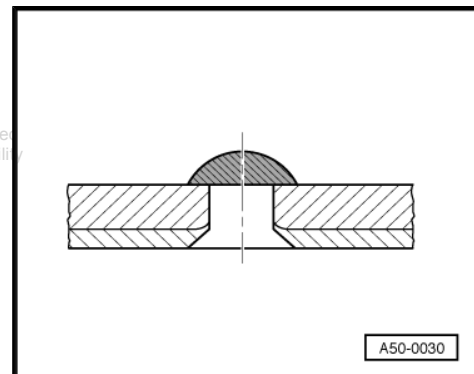

Fitting a full rivet

- Adjust new parts, apply glue and attach new part to body.
- Remove the flanges using a riveting tool.

When driving out, punching and embossing are carried out during the work process.

Note

For all work, adjust the riveting device to the thickness of the material. To prevent protruding flanges from being perforated, insert staples into the pressed openings.

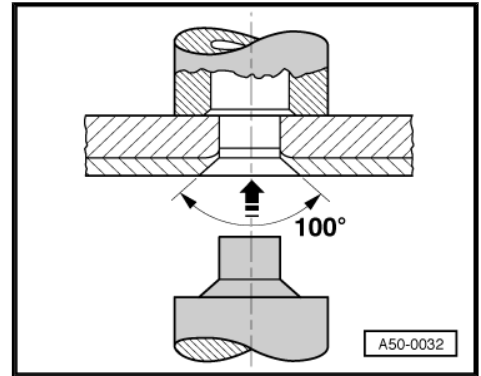

- Fasten the rivet and insert the rivet head with the rivet.

There are corresponding inserts available for different rivet diameters for the riveting machine.

Note

- ◆ *Contrary to series production all rivet connections are also attached by the customer service team. See adhesive bonding => "7.1 Gluing", page 32. A full rivet is made of aluminum.*
- ◆ *There are various full rivets available, observe the vehicle-specific repair instructions in this regard.*

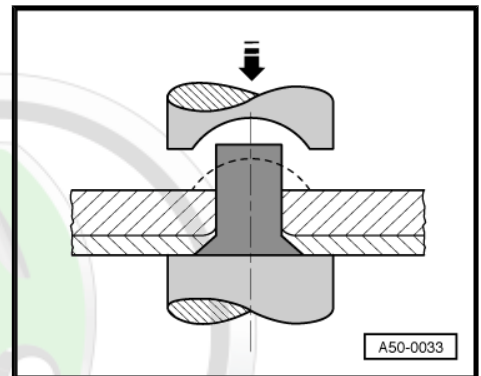

7.2.2 Pop rivet

Open the blind rivet

- If necessary, Carry out separation cuts.
- Drill out the blind rivet, drilling diameter 4.5 mm.
- Remove the damaged part, cut it off with a chisel, if required.

WARNING

Collect remains of the blind rivet! If the remains fall into the cavities and can not be removed, they must be connected with wax in cavities.

unless authorised by ŠKODA AUTO A. S. ŠKODA AUTO A. S. does not guarantee or accept any liability with respect to the correctness of information in this document. Copyright © ŠKODA AUTO A. S.

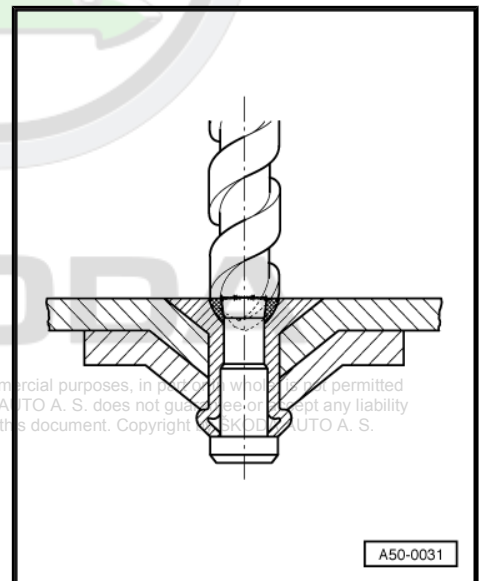



Fit the blind rivet

- Adjust new parts, fit to the car body and fasten.
- Drill the new part and old part your own material drill through one another, \varnothing 2.5 mm.
- Remove new parts.
- Drill holes with rivet tool in all parts.



Note

- ◆ For all work, adjust the riveting device to the thickness of the material. The diameter is increased to 4.8 mm when driven out. The embossing must show in all parts inwards.
- ◆ Extruded profiles can not be driven out. Lower new part with extruded profile, remove part and drill the extruded profile to \varnothing 4.8 mm.

- Apply adhesive.
- Insert blind rivet and pull pin with rivet pliers.



Note

- ◆ Contrary to series production all rivet connections are also attached by the customer service team. See [⇒ "7.1 Gluing", page 32](#) Adhesive bonding.
- ◆ There are various blind rivets available, observe the vehicle-specific repair instructions in this regard.

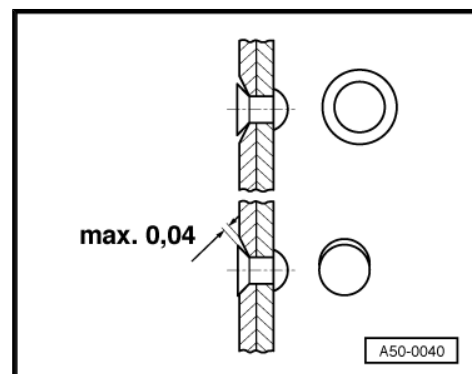
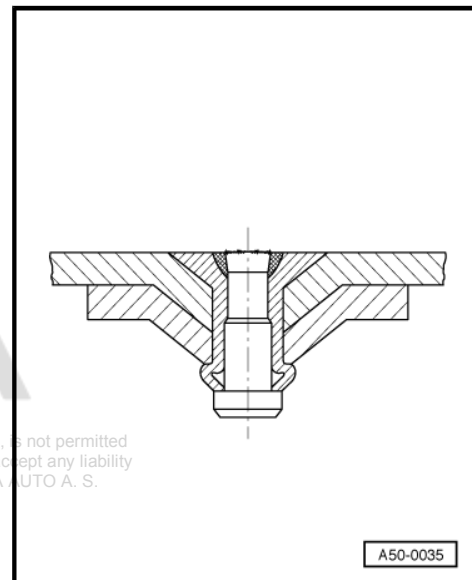
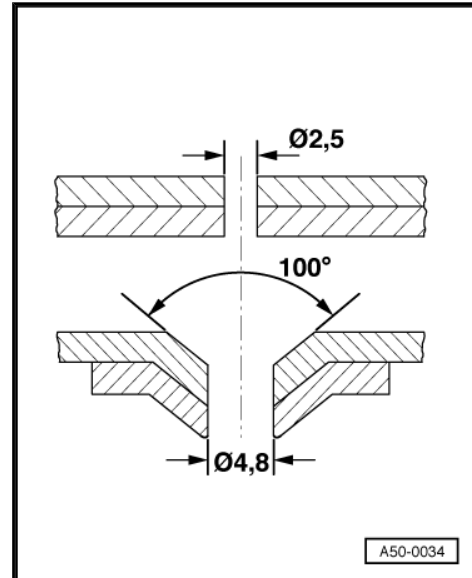

Protected by copyright. Copying for private or commercial purposes, in part or in whole, is not permitted unless authorised by ŠKODA AUTO A. S. ŠKODA AUTO A. S. does not guarantee or accept any liability with respect to the correctness of information in this document. Copyright by ŠKODA AUTO A. S.

7.2.3 Rivet faults

Open countersinks

Open recesses on the entire circumference are not permitted. Partial open recesses up to a gap width of 0.04 mm are permissible.

Impacts, e.g. with a curved pressure ram, are permissible if tolerances for the closing and setting head are observed.



Non-adjacent rivet heads

Loose rivets are generally not permitted.
A partial gap of up to 0.05 mm is permissible.

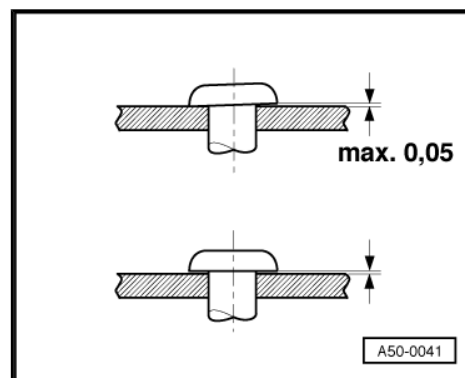

The rivet connection buckling

During riveting, the rivet material is forced into the gap causing rivet stress in the bend.

Buckles of this type are not permitted!

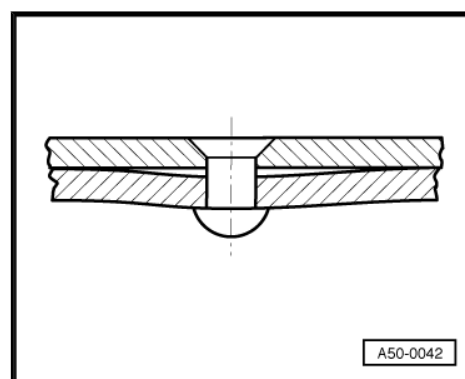

Buckles between rivet connections

The gap width must not exceed 0.3 mm.

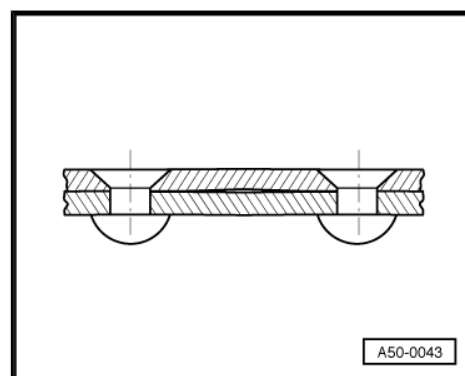

Shearing cracks

Cracks which are not cut through (above) are permissible.

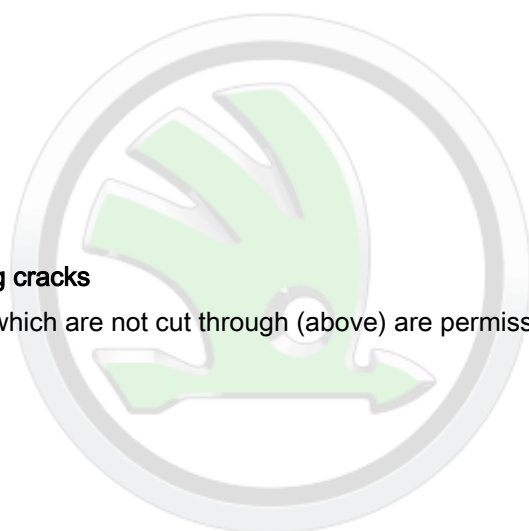
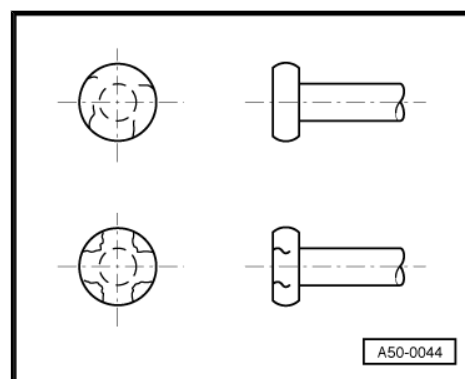

ŠKODA

Protected by copyright. Copying for private or commercial purposes, in part or in whole, is not permitted unless authorised by ŠKODA AUTO A. S. ŠKODA AUTO A. S. does not guarantee or accept any liability with respect to the correctness of information in this document. Copyright by ŠKODA AUTO A. S.



Notches

Permissible incision depth is $1/4 * \text{height of the head}$.

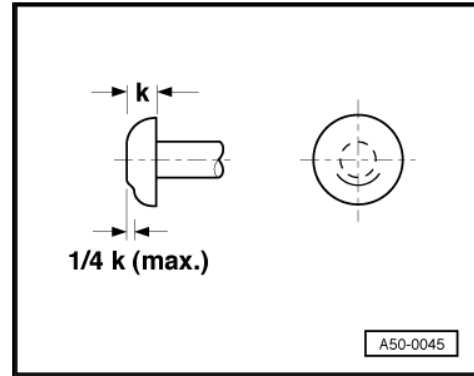

Rings

Rings in the closing head are produced by using a small pressure ram.

Permissible ring depth is $1/4 * \text{height of the head}$.

Complete ring formation is not permitted.

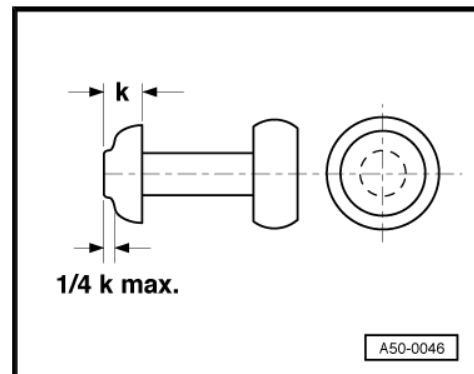

Offset closing head

Offset head is not permitted as soon as the closing head touches the hole ring and a hole is visible in the rivet.

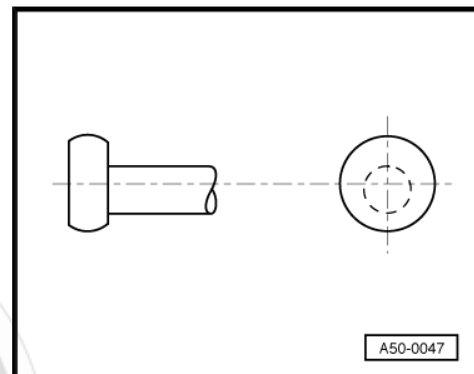

7.2.4 Notch-cone rivets

Stainless steel-coated notch cone rivets are used.



Note

Stainless steel rivets must not be drilled or sanded due to the risk of corrosion.

ŠKODA

Protected by copyright. Copying for private or commercial purposes, in part or in whole, is not permitted unless authorised by ŠKODA AUTO A. S. ŠKODA AUTO A. S. does not guarantee or accept any liability with respect to the correctness of information in this document. Copyright by ŠKODA AUTO A. S.



Handling rivets

- A - Fitting a rivet
- B - Pressing process
- C - Pressing in and driving out
- D - Finished connection with notch cone rivet

Gauges, instruments

Only approved instruments according to ⇒ ŠKODA AUTO a. s. workshop standards may be used.

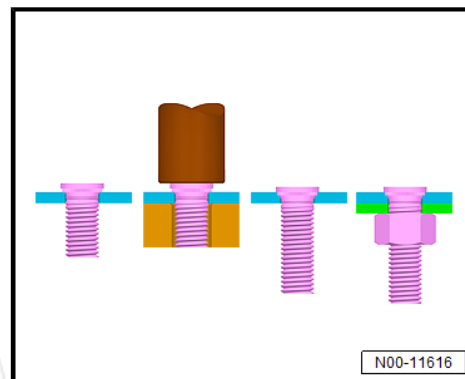

7.3 Overview - Pairing riveting tools



Note

- ◆ *This map is for orientation only. Please refer to the enclosed Owner's Manual for working description and usage.*
- ◆ *In order to increase the service life of the riveting tools, common cutting oil must be used.*

ŠKODA

Protected by copyright. Copying for private or commercial purposes, in part or in whole, is not permitted unless authorised by ŠKODA AUTO A. S. ŠKODA AUTO A. S. does not guarantee or accept any liability with respect to the correctness of information in this document. Copyright by ŠKODA AUTO A. S.



D 1 + D 2 - Ø 3.2 mm - press rivet

D 2 + D 3 - Ø 3.2 mm - press rivet

D 2 + D 5 - Ø 5 mm - press rivet

D 3 + D 5 - Ø 5 mm - press rivet

D 4 + D 5 - Ø 5 mm - press rivet

D 5 + D 12 - Open Ø 8 mm opening - hole for welded connection

D 6 + D 7 - Open the opening for Ø 4.8 mm - blind rivet

D 8 + D 8 - Reshaping the sheet

D 8 + D 9 - Press in Ø 4 mm - Full rivet

D 10 + D 11 - Drive out Ø 4 mm - Full rivet

D 13 + D 14 - Ø 5.3 x 7.5 mm - press rivet

D 17 + D 17 - Reshaping the sheet

D 15 + D 16 - Open the opening for Ø 6.0 mm - full rivet

D 17 + D 17 - Press in Ø 6.0 mm - Full rivet

S 1 + D 2 - Ø 3.2 mm - press rivet

S 2 + S 3 - Fit Ø 3.2 mm - press rivet

S 4 + D 5 - Ø 5.3 x 5.5 mm - press rivet

S 5 + D 5 - Ø 5.3 x 6.5 mm - press rivet

S 6 + S 7 - Fit Ø 5.3 x 5.5 mm - press rivet

S 6 + S 8 - Fit Ø 5.3 x 6.5 mm - press rivet

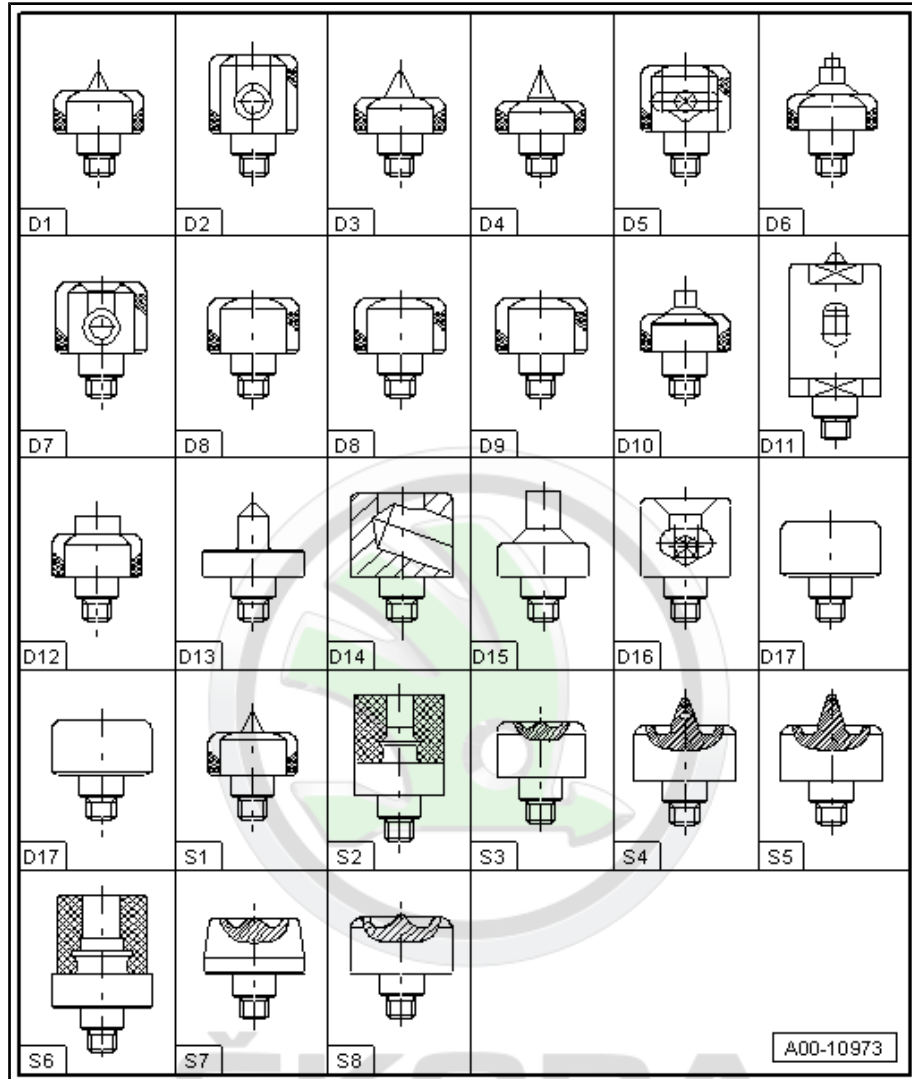

Protected by copyright. Copying for private or commercial purposes, in part or in whole, is not permitted without the prior written authorisation of SKODA AUTO A. S. SKODA AUTO A. S. does not guarantee or accept any liability with respect to the correctness of information in this document. Copyright by SKODA AUTO A. S.

7.4 FDS screws (flow drill screws)

In the case of flow drill screws, the lower component is heated by heat that is generated when the rotating screw is rotating. Then the thread-tapping screw (flow-drill screw) is screwed into the soft aluminium.

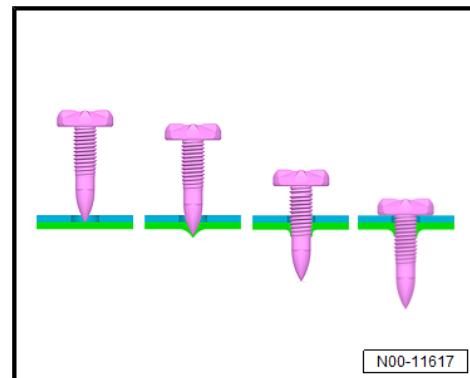

7.5 Pressing through

Pressing through is a connection method by pressing the sheet metal connection without using an additional material. It can be calculated for the connection methods, as well as forming methods, because the connection is achieved by material shaping.

Repair instructions

- If necessary, Carry out separation cuts.
- Remove the old flange by peeling it off.
- Balance the remaining flange.



Note

For all work, adjust the riveting device to the thickness of the material.

- Remove the damaged part, cut it off with a chisel, if required.
- Fit the new parts and retract the full or blind rivet according to the "Body repairs" repair booklet.

Gauges, instruments

Only approved instruments according to ⇒ ŠKODA AUTO a. s. workshop standards may be used.

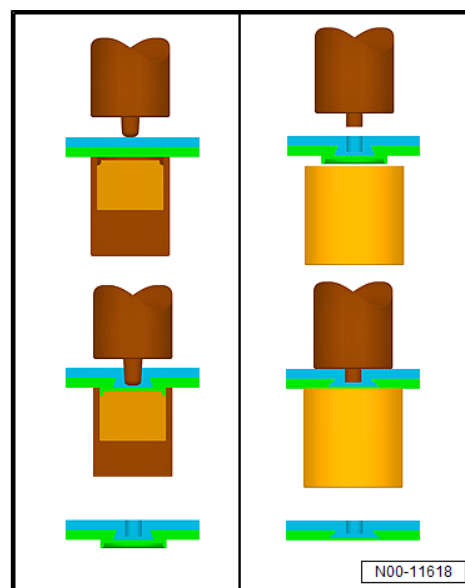

ŠKODA



8 Cutting techniques for body repairs; areas of application

⇒ [“8.1 Bore”, page 40](#)

⇒ [“8.2 Cutting”, page 40](#)

⇒ [“8.3 Sanding”, page 40](#)

⇒ [“8.4 Milling”, page 41](#)

⇒ [“8.5 Remove adhesive bonds”, page 41](#)

8.1 Bore

The bore is used to loosen the spot welding seams of spot welding and riveting. When drilling, ensure that the components at the rear are not damaged. When the two- and multi-layer welded joints are released, the sheet remaining on the vehicle must not be reduced any more than is necessary. Before drilling out of the cavities, carefully remove any chips (vacuum).

8.2 Cutting

When cutting, a distinction is made between two commonly used device types:

- ◆ pneumatic saw with short stroke
- ◆ Oscillating saw

Advantages of pneumatic saws with short stroke:

- ◆ Quick cutting.
- ◆ Radius cutting can be carried out.
- ◆ It can also be used with profiles that have been significantly shaped.

Advantages of oscillating saws:

- ◆ Clean straight cuts.
- ◆ Low penetration depth, therefore especially suitable for double-walled sheets.



Note

Before cutting from the cavities, carefully remove any chips (vacuum).

8.3 Sanding

Grinding can be a very sensible alternative to drilling, especially when loosening high-strength welded joints. Welding points, laser seams or soldering seams can be loosened very easily by grinding. Again, care must be taken that the materials do not become weaker than necessary, do not damage them.

Disadvantages of grinding:

- ◆ Because of the sparks, valuable safety precautions are required on the vehicle and in its surroundings.
- ◆ Higher temperatures than during drilling, which is why environmental and corrosion protection damage is impaired.

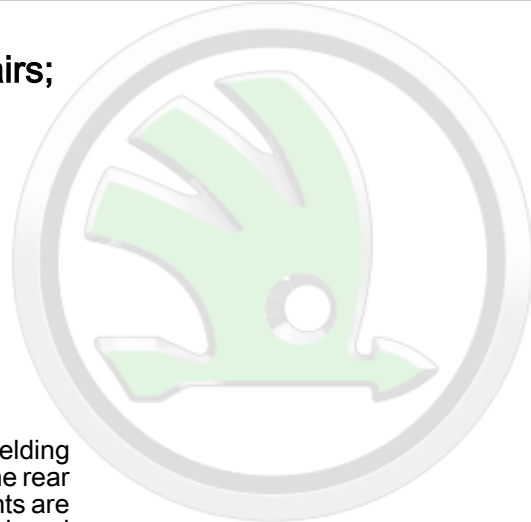

ŠKODA

Protected by copyright. Copying for private or commercial purposes, in part or in whole, is not permitted unless authorised by ŠKODA AUTO A. S. ŠKODA AUTO A. S. does not guarantee or accept any liability with respect to the correctness of information in this document. Copyright by ŠKODA AUTO A. S.



8.4 Milling

In the case of bodywork repairs, a distinction is drawn between ball milling -A- and BTR milling -B-.

Spherical milling is used when spatial conditions do not allow the use of BTR milling to loosen the spot welding seams.

When working with BTR milling cutters, make sure that the milling cutter is not misaligned. Due to the milling distortion, it can easily be bent. No drills should be used with regard to the milling design.

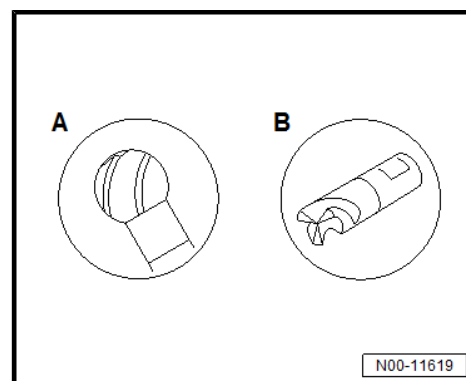

8.5 Remove adhesive bonds

Adhesive surfaces of the body can be detached by heating the connection.



WARNING

When the adhesive joints are released, toxic gases are formed, which is why good room ventilation and suitable smoke extraction are important.



ŠKODA

Protected by copyright. Copying for private or commercial purposes, in part or in whole, is not permitted unless authorised by ŠKODA AUTO A. S. ŠKODA AUTO A. S. does not guarantee or accept any liability with respect to the correctness of information in this document. Copyright by ŠKODA AUTO A. S.



9 Repairing surfaces

⇒ [“9.1 Bulking sheet steel techniques”, page 42](#)

⇒ [“9.2 Metal and aluminium mastic”, page 43](#)

⇒ [“9.3 Lead-free tin processing”, page 43](#)

⇒ [“9.4 Definition of properly shaped surface / Delivery to the paint shop”, page 44](#)

9.1 Bulking sheet steel techniques

⇒ [“9.1.1 Classic bulking \(with varnish damage\)”, page 42](#)

⇒ [“9.1.2 Bulking by pressing \(without lacquer damage\)”, page 42](#)

⇒ [“9.1.3 Bulking bulking outwards/ removing”, page 42](#)

9.1.1 “Classic” bulking (with varnish damage)



Note

During bulking work, ensure there is corrosion protection on the inside!

The disadvantage of this technique is, firstly, limited usability (design visibility) as well as excessive stress on the material caused by the method. The material surplus resulting from this must often be extruded while warm, which again creates considerable disadvantages for material strength and corrosion protection.

9.1.2 Bulking by “pressing” (without lacquer damage)



Note

During bulking work, ensure there is corrosion protection on the inside!

The bulking technique without lacquer damage is mostly used with minor damage. The indentation is easily pressed from the inside to the outside. Thereby, the centre of the depression is pressed in several steps.

A - Example pressure set

9.1.3 Bulking “bulking outwards/ removing”



Note

Protected by copyright. Copying for private or commercial purposes, in part or in whole, is not permitted unless authorised by ŠKODA AUTO A. S. ŠKODA AUTO A. S. does not guarantee or accept any liability with respect to the correctness of information in this document. Copyright by ŠKODA AUTO A. S.

During bulking work, ensure there is corrosion protection on the inside!

The outdoor bulking technique is not only used as an adhesive technique without lacquer damage, but also as a technique with lacquer damage, due to welding of drawing bits. The selected method depends on the type of damage. In both methods, the indentation is extruded from outside the sheet. By re-forming slow, the material structure is considerably less stressed.

Advantages of this technique:

- ◆ Reduced excess material elongation.
- ◆ Corrosion protection for minor damage.
- ◆ Reduced demand for expansion in the vehicle.
- ◆ Get original part (replace part if necessary).

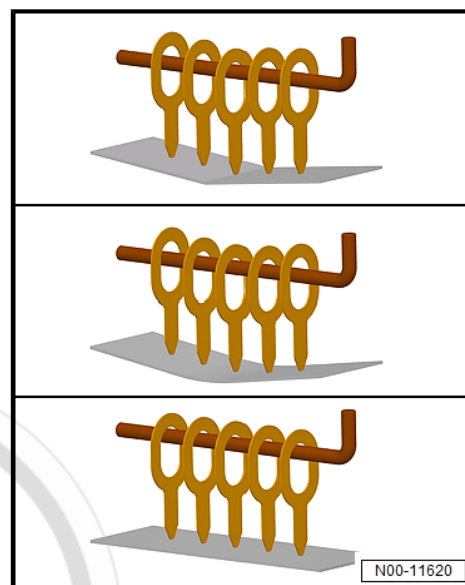

9.2 Metal and aluminium mastic

Processing metal and aluminum mastic has many advantages:

- ◆ Very good adhesion to non-painted surfaces.
- ◆ When used professionally, there is a small tendency to “overlap” or “lower” at the end.
- ◆ Due to slight heating, it can also be used in adhesive areas.
- ◆ No border marking in transition areas.

Note

Only approved mastics may be used.

WARNING Protected by copyright. Copying for private or commercial purposes, in part or in whole, is not permitted unless authorised by ŠKODA AUTO A. S. ŠKODA AUTO A. S. does not guarantee or accept any liability with respect to the correctness of information in this document. Copyright by ŠKODA AUTO A. S.

- ◆ *Follow the instructions for processing on the containers.*
- ◆ *Before applying the sealant, remove glue residues, basic residues and the like from the crevices.*
- ◆ *The surface temperature must be checked when drying by using infrared radiators.*
- ◆ *Infrared emitters with their own control system have a tendency to present measurement errors on smaller surfaces, which can lead to damage to the components.*

9.3 Lead-free tin processing

Note

- ◆ *It is no longer permissible to process tin as well as lead-free tin.*
- ◆ *To create a properly formed surface, materials approved by the manufacturer must be used.*



9.4 Definition of “properly shaped surface” / Delivery to the paint shop

A correctly shaped surface is the surface with dimensional accuracy of edges and depressions from the surface.

It is given for:

- ◆ Parts and parts machined by the car body specialist, after sanding, welding or dry filling, are ground with a minimum particle size of 80 mm
- ◆ Body finishing work completed



ŠKODA

Protected by copyright. Copying for private or commercial purposes, in part or in whole, is not permitted unless authorised by ŠKODA AUTO A. S. ŠKODA AUTO A. S. does not guarantee or accept any liability with respect to the correctness of information in this document. Copyright by ŠKODA AUTO A. S.



10 Straightening the vehicle

⇒ [“10.1 Alignment”, page 45](#)

⇒ [“10.2 Separation cuts”, page 45](#)

⇒ [“10.3 Bodyshell offcut sections and parts”, page 45](#)

10.1 Alignment

The bodyshell and the body platform are manufactured from cold-formed deep-drawing panels in series production. For this reason, the reverse deformation must be done in the same way.



Note

When aligning kinks with sharp edges, there is a risk that the panel will suddenly tear.

If the extent of damage no longer allows for a reverse deformation against the direction of the accident, the damaged part must not be cut out until after the connection surfaces have been aligned.

10.2 Separation cuts

Separation cuts having an influence on the form stability of the bodyshell and thus the operating and on-road safety of the vehicle, must be repaired in accordance with the instructions in this Workshop Manual.

10.3 Bodyshell offcut sections and parts

“Offcut sections” are offcuts of single parts which are delivered pre-cut to the required dimensions by the spare parts warehouse.

“In contrast, parts” must be cut from the spare parts to the required dimensions.



11 Corrosion prevention

⇒ ["11.1 Long-term body protection", page 46](#)

⇒ ["11.2 Body long-term protection if filling is needed", page 46](#)

11.1 Long-term body protection

The body is manufactured in sheet metal galvanized on both sides.

The standard protection against corrosion must be restored after repairs by using the materials recommended by the manufacturer, as this is indispensable in order to guarantee corrosion does not occur.

- Apply a corrosion protection, e.g., 2K Wash Primer - LLS MAX 230 M1- and, e.g., 2K filler - LLS MAX 202 M2- onto bright sheet metal within 20 minutes after the repair ⇒ General paint information; 00 technical data; original products.
- Use, e.g., sealing compound - AKD 476 KD5 05- to seal the panel overlaps, panel sides, butt joints, welding seams etc. completely ⇒ General paint information; 00 technical data; original products.
- Restore the vehicle protection protection.
- After applying the finish paint protect all the hollow spaces near the repair location.
- Unlock all water drainage openings once the hollow space protection material has dried.

11.2 Body long-term protection if filling is needed

The body is manufactured in sheet metal galvanized on both sides.

The standard protection against corrosion must be restored after repairs by using the materials recommended by the manufacturer, as this is indispensable in order to guarantee corrosion does not occur.

- E.g., apply metal filler - DA 787 300 A2- to bright sheet metal only and treat the repair spot against corrosion next ⇒ ["11.1 Long-term body protection", page 46](#) .
- Use, e.g., sealing compound - AKD 476 KD5 05- to seal the panel overlaps, panel sides, butt joints, welding seams etc. completely ⇒ General paint information; 00 technical data; original products.
- Restore the vehicle protection protection.
- After applying the finish paint protect all the hollow spaces near the repair location.
- Unlock all water drainage openings once the hollow space protection material has dried.



ŠKODA

Protected by copyright. Copying for private or commercial purposes, in part or in whole, is not permitted unless authorised by ŠKODA AUTO A. S. ŠKODA AUTO A. S. does not guarantee or accept any liability with respect to the correctness of information in this document. Copyright by ŠKODA AUTO A. S.



12 Plastic repair

⇒ [“12.1 Plastic repair”, page 47](#)

⇒ [“12.2 Repairing indentations”, page 47](#)

⇒ [“12.3 Repairing scratches”, page 49](#)

⇒ [“12.4 Repairing a crack \(up to 100 mm length\)”, page 50](#)

⇒ [“12.5 Repairing a hole \(up to 30 mm diameter\)”, page 51](#)

⇒ [“12.6 Plastic repair \(GRP\)”, page 52](#)

12.1 Plastic repair



WARNING

Please observe the general accident prevention regulations. Safety-relevant parts which, after a repair, no longer guarantee function, e.g. absorbing forces, may not be repaired.

Plastic part repair with a plastic repair kit is defined as a repair of painted plastic body parts. For example, bumper and mirror housing. Prior to repair, care should be taken to check whether the repair is feasible and from an economic standpoint (repair / new part).

Plastic parts with a structured surface can also be repaired. But a surface quality like the new part is not always achieved to its fullest extent.

12.2 Repairing indentations

ŠKODA

Protected by copyright. Copying for private or commercial purposes, in part or in whole, is not permitted unless authorised by ŠKODA AUTO A. S. ŠKODA AUTO A. S. does not guarantee or accept any liability with respect to the correctness of information in this document. Copyright by ŠKODA AUTO A. S.

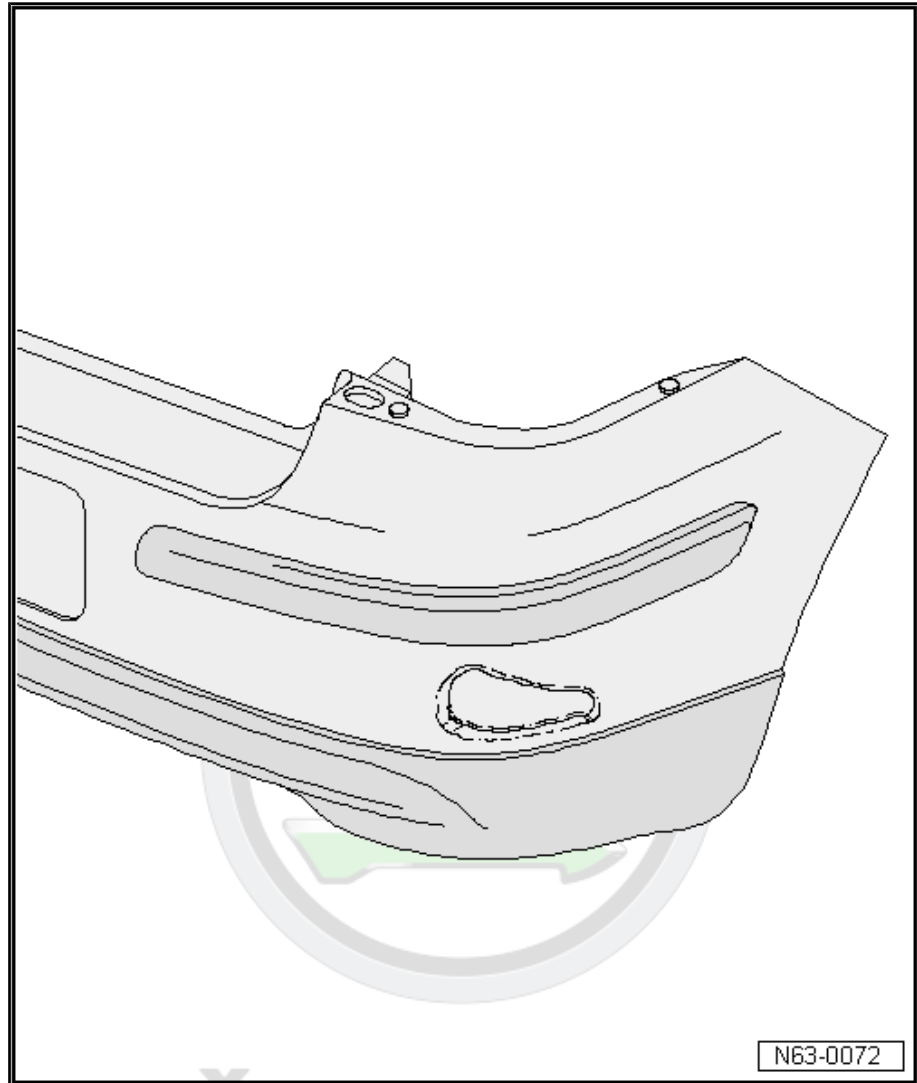

- Clean and dry the repair part first.
- Now heat the area of the bump with the hot air blower until it can be pressed out with a suitable tool.
- Now sand the area of the bump with sandpaper grade P120.
- Then clean the repair area with the cleaner. The flash-off time is 5 minutes.
- Spray the adhesion agent thinly and observe a flash-off time of 10 minutes.
- Now you can fill up the remaining unevenness with the adhesive and smooth it with a spatula.
- With an infrared radiator you can accelerate curing. Set it to 15 minutes at 60 ... 70 ° C.
- Now sand the repair site with sandpaper grade P120.
- Now remove the sanding dust.
- Lacquer construction should be carried out according to the repair booklet chapter on lacquer.

12.3 Repairing scratches

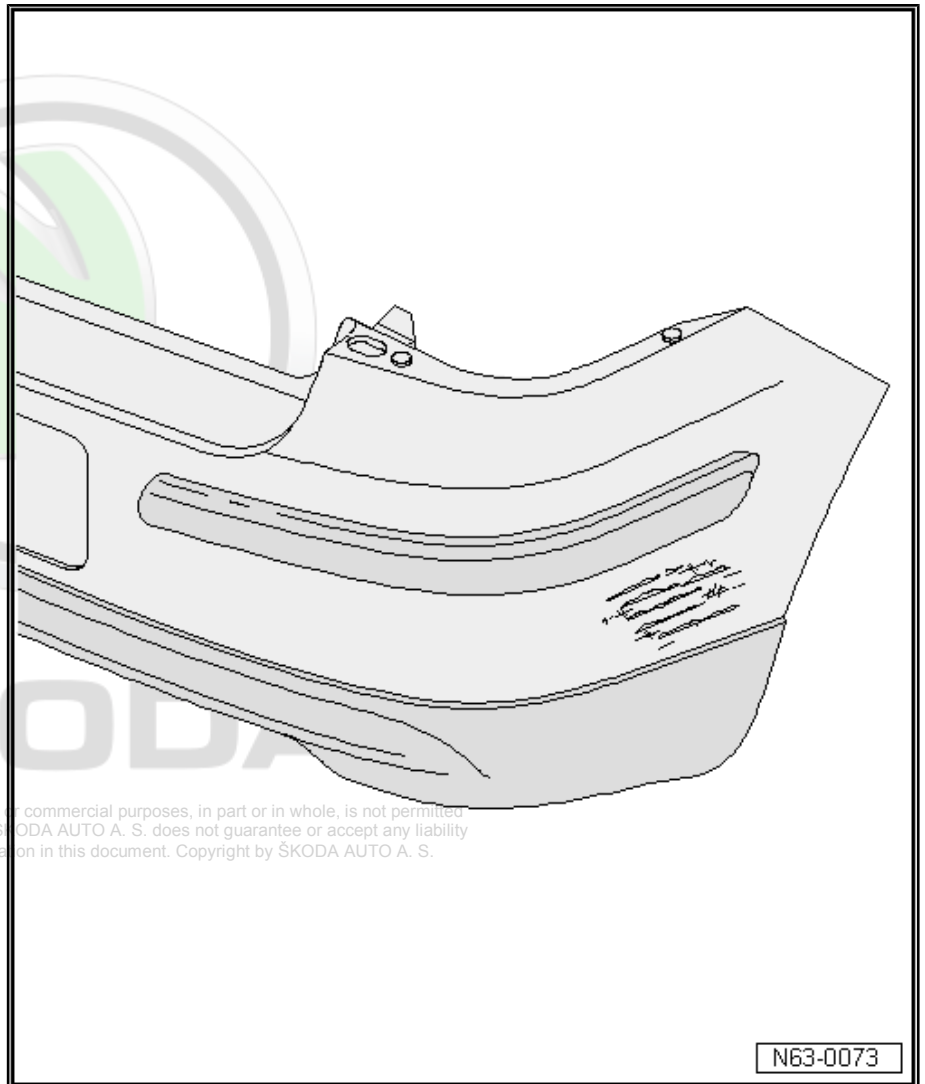

Protected by copyright. Copying for private or commercial purposes, in part or in whole, is not permitted unless authorised by ŠKODA AUTO A. S. ŠKODA AUTO A. S. does not guarantee or accept any liability with respect to the correctness of information in this document. Copyright by ŠKODA AUTO A. S.

- Clean and dry the repair part first.
- With abrasive paper P80, you can remove the protruding material.
- Then clean the repair area with the cleaner. The flash-off time is 5 minutes.
- Spray the adhesion agent thinly and observe a flash-off time of 10 minutes.
- Now you can fill up the remaining unevenness with the adhesive and smooth it with a spatula.
- With an infrared radiator you can accelerate curing. Set it to 15 minutes at 60 ... 70 ° C.
- Now sand the repair site with sandpaper grade P120.
- Now remove the sanding dust.
- Lacquer construction should be carried out according to the repair booklet chapter on lacquer.



12.4 Repairing a crack (up to 100 mm length)

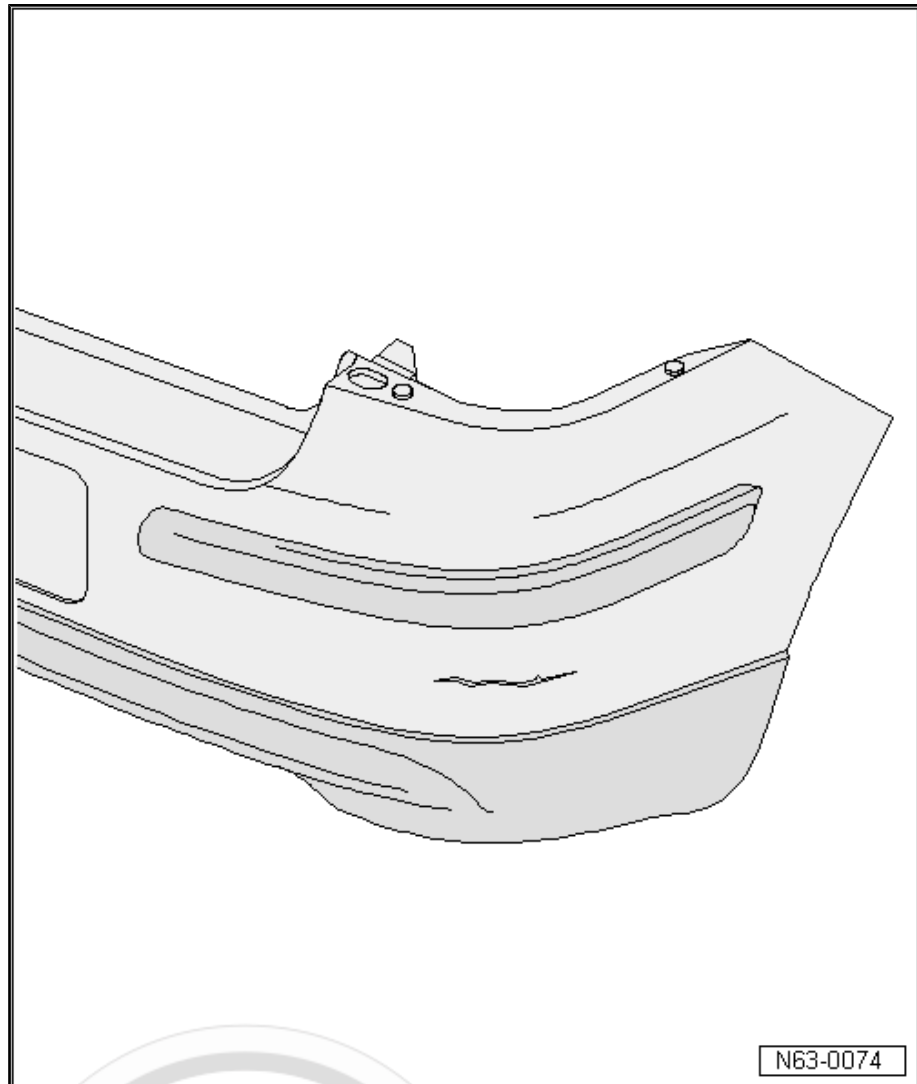

- Clean and dry the repair part first.
- By drilling and grinding the crack in a V-shape, you can remove any unevenness caused by overstretching. Roughen with P120.
- Then clean the repair area with the cleaner. The flash-off time is 5 minutes.
- Spray the adhesion agent thinly and observe a flash-off time of 10 minutes.
- First, you should use a reinforcing fleece on the back of the repair part with the adhesive, so that it overlaps the damage area at least 20 mm.
- With an infrared radiator you can accelerate curing. Set it to 15 minutes at 60 ... 70 ° C.
- Then you can fill the point that have been grounded out with the glue on the front and smooth it with a spatula.
- you should also accelerate the curing with the infrared radiator as mentioned above on the front.
- Now sand the repair site with sandpaper P120.

commercial purposes, in part or in whole, is not permitted unless authorised by ŠKODA AUTO A. S. ŠKODA AUTO A. S. does not guarantee or accept any liability with respect to the correctness of information in this document. Copyright by ŠKODA AUTO A. S.

- Now remove the sanding dust.
- Lacquer construction should be carried out according to the repair booklet chapter on lacquer.

12.5 Repairing a hole (up to 30 mm diameter)

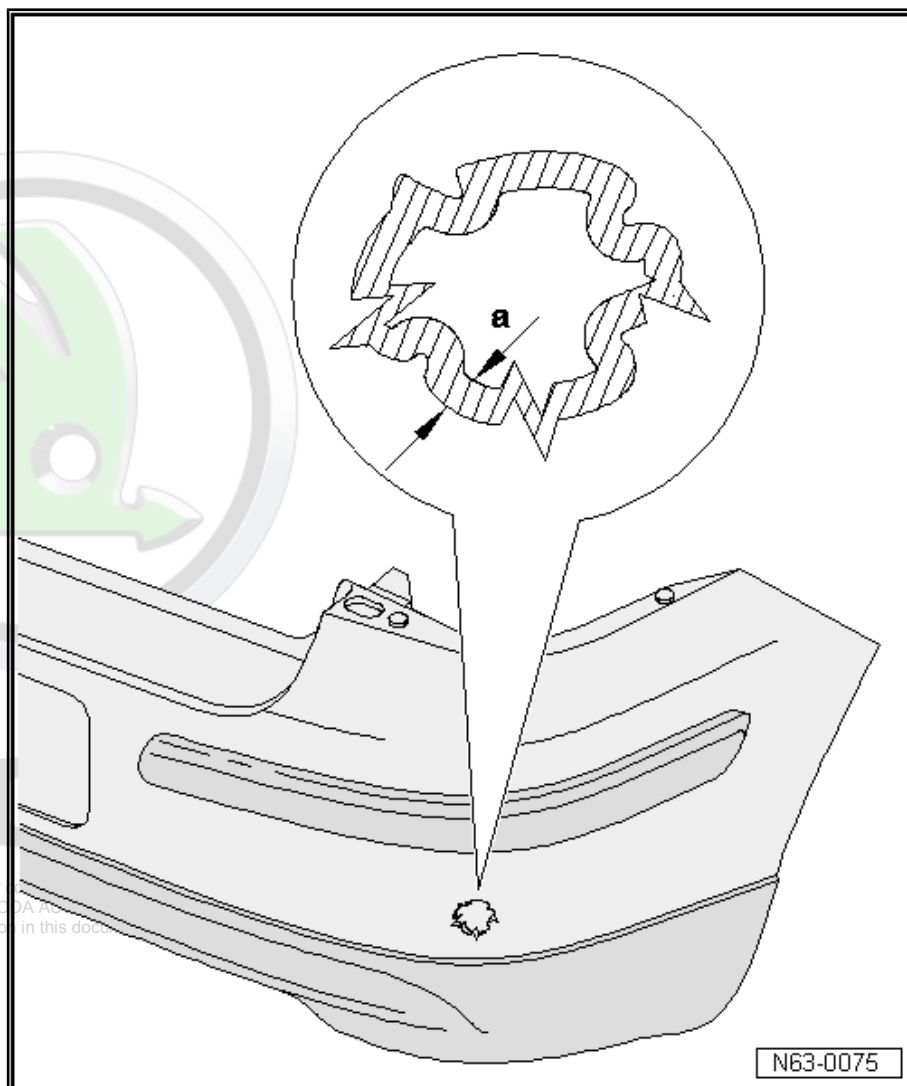

Protected by copyright. Copying for private or internal use is permitted without prior written permission of ŠKODA AUTO A. S. ŠKODA AUTO A. S. reserves the right to change the content of this document without notice. The publisher is not responsible for the correctness of information in this document.

- Clean and dry the repair part first.
- With sandpaper P120, you should sand the funnel-shaped repair site 10-20 mm, dimension a.
- Then clean the repair area with the cleaner. The flash-off time is 5 minutes.
- Spray the adhesion agent thinly and observe a flash-off time of 10 minutes.
- First, you should use a reinforcing fleece on the back of the repair part with the adhesive, so that it overlaps the damage area at least 20 mm.
- With an infrared radiator you can accelerate curing. Set it to 15 minutes at 60 ... 70 ° C.
- Then you can fill the point that have been grounded out with the glue on the front and smooth it with a spatula.



- you should also accelerate the curing with the infrared radiator as mentioned above on the front.
- Now sand the repair site with sandpaper grade P120.
- Now remove the sanding dust.
- Lacquer construction should be carried out according to the repair booklet chapter on lacquer.

12.6 Plastic repair (GRP)

⇒ ["12.6.1 Repair process breakage point", page 53](#)

⇒ ["12.6.2 Repairing surface damage", page 54](#)

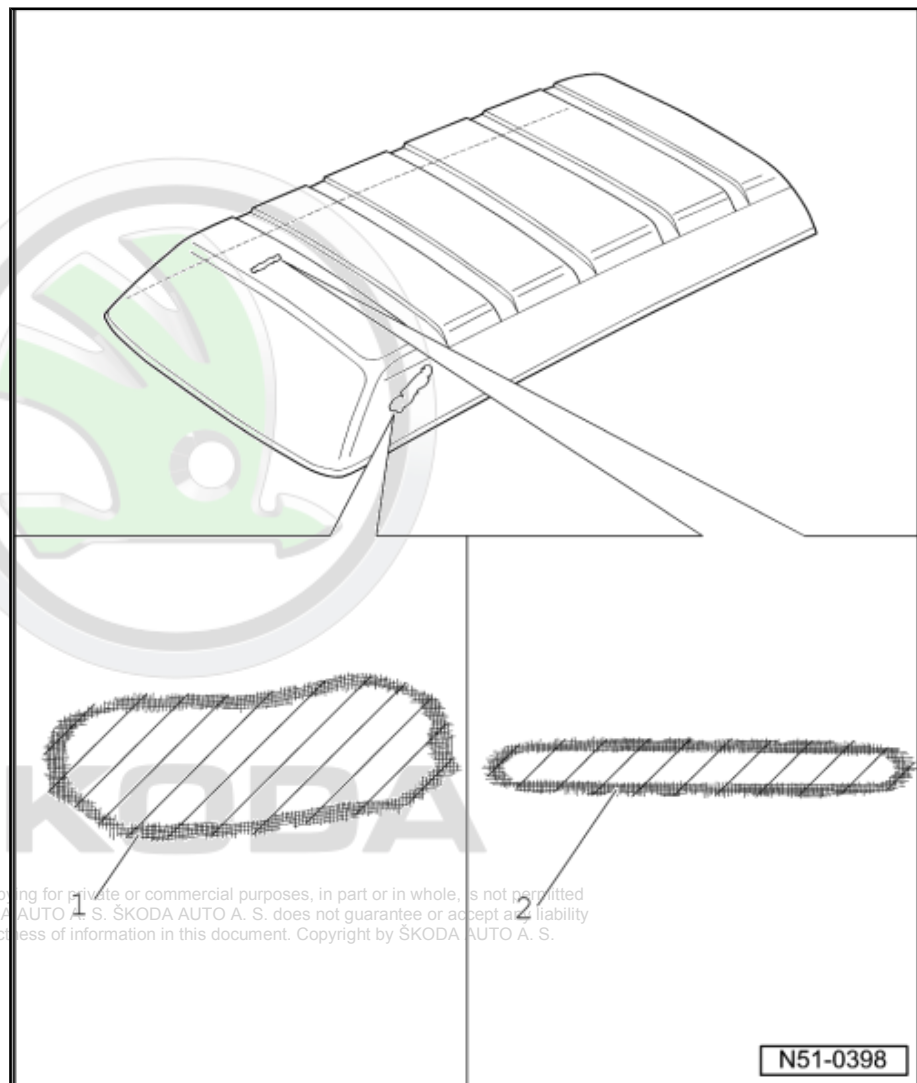

WARNING

Please observe the general accident prevention regulations. Safety-relevant parts which, after a repair, no longer guarantee function, e.g. absorbing forces, may not be repaired.

1.- Breakage point

- ◆ Fibreglass mat, polyester resin and hardener

2.- Surface damage

- ◆ Glass fibre-reinforced polyester resin, hardener

i Note

For processing the materials, please refer to the manufacturer's instructions for use.

12.6.1 Repair process "breakage point"

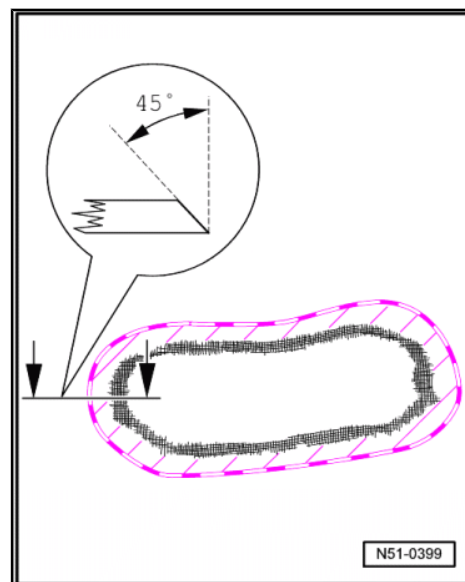

- Sand the edge of the breakage point at an angle of approx. 45



Protected by copyright. Copying for private or commercial purposes, in part or in whole, is not permitted unless authorised by ŠKODA AUTO A. S. ŠKODA AUTO A. S. does not guarantee or accept any liability with respect to the correctness of information in this document. Copyright by ŠKODA AUTO A. S.

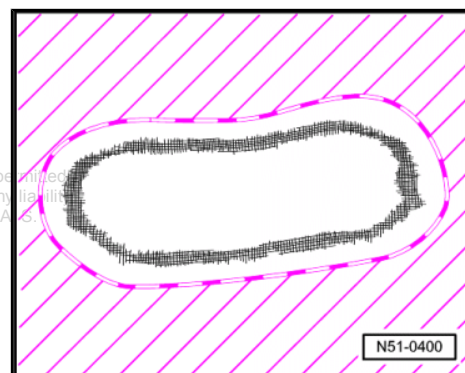

- Sand surface, approx. 100 mm in circumference around the breakage point (hatched area) with P150er sandpaper and clean with silicone remover.
- Cut three glass fiber mats to size: -1- approx. 25 mm overlapping the breakage point, -2- about 50 mm overlapping, -3- cut approx. 75 mm overlapping.

i Note

For larger brakages, it is advisable to make a support made of styrofoam. Coat the polystyrene with an uncovered, commercially available PE plastic film to prevent contact with polyester resin. Then attach the prepared support to the inside of the breakage site with adhesive tape.

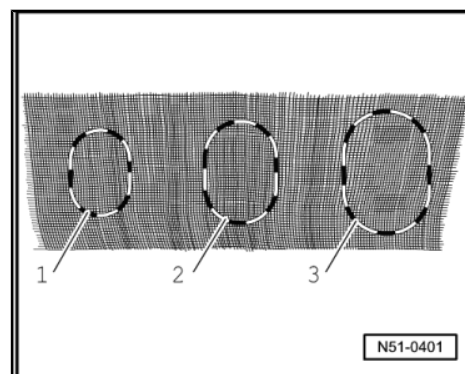



Apply fibreglass mats.

- Polyester resin (observe the manufacturer's instructions for use).
- Thinly apply polyester resin to the fracture site.
- Soak the smallest glass fiber mat -1- with polyester resin and apply to the breakage site -4-.
- Air bubbles in the polyester resin must be removed immediately after application with a sharp tool.
- After curing, plane the applied material with P120 sandpaper.
- Clean the repair point with silicone remover.
- Repeat the process with the second -2- and third -3- fibreglass mat.

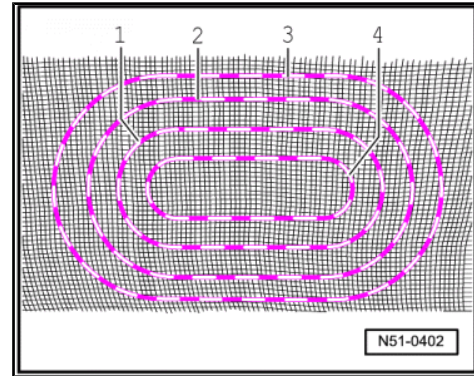

12.6.2 "Repairing surface damage"

- Grind the surface in a V-shape.
- Sand the surface, approx. 50 mm circumference to the surface damage (hatched area) with P150er sandpaper.

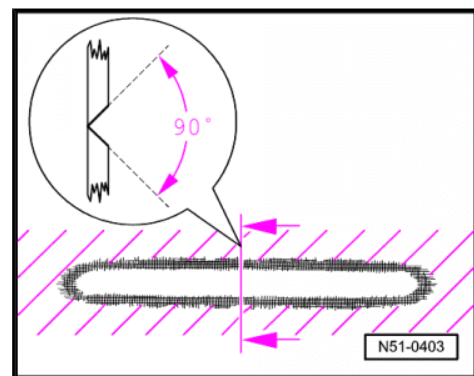

- Clean the repair point with silicone remover.
- Mix the glass fiber reinforced polyester resin (observe the manufacturer's instructions) and place it on the repair area (hatched area).
- Repair site after hardening and sanding with a silicone remover.

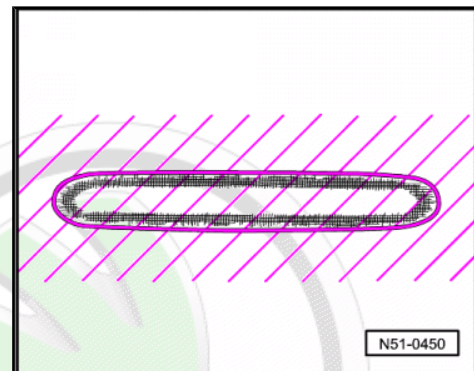

ŠKODA

Protected by copyright. Copying for private or commercial purposes, in part or in whole, is not permitted unless authorised by ŠKODA AUTO A. S. ŠKODA AUTO A. S. does not guarantee or accept any liability with respect to the correctness of information in this document. Copyright by ŠKODA AUTO A. S.

13 Glass repair

⇒ "13.1 Front window repair", page 55

13.1 Front window repair

In addition to the replacement of glued front windscreens, there is the option, under certain conditions, of a more cost-effective way to repair front windscreens.

Tinted windows, partly dyed windows or darkened and heated windows can also be repaired, since tinting and the heating are carried out by the coloured intermediate film.

Repair requirements

- The damage site must not be within the direct field of view -1-. This field corresponds to an approximately 29 cm wide strip (DIN A4 format transversely) to the driver's direct direction of view in the direction of travel, limited by the windshield wiper area at the top and bottom.
- Cracks originating from the damage site -2- must not be longer than 50 mm and / or do not extend outwards into the edge area.
- The diameter of the impact point -1- should not be more than 5 mm.
- The intermediate film -2- or the inner disc -3- must not be damaged.
- No dirt or moisture may penetrate into the lower cracks.
- Therefore, the time of the damage should be any longer.

"Cow eye"

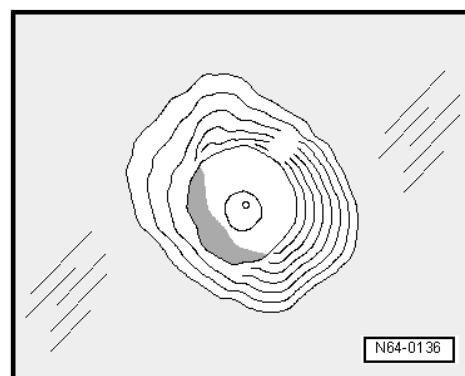
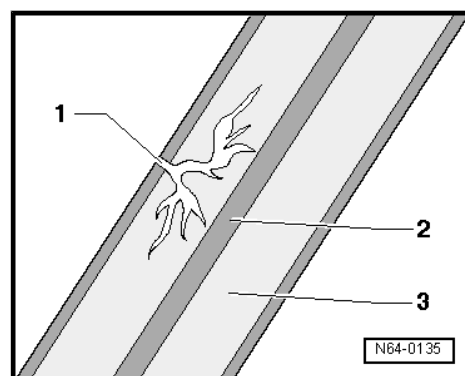
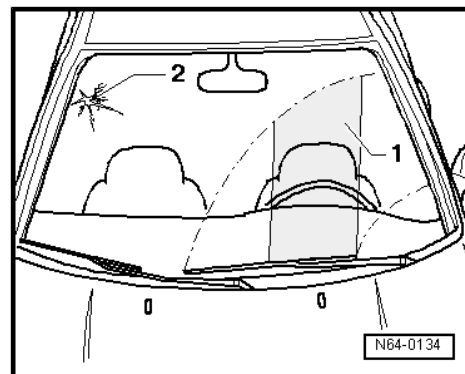

ŠKODA

Protected by copyright. Copying for private or commercial purposes, in part or in whole, is not permitted unless authorised by ŠKODA AUTO A. S. ŠKODA AUTO A. S. does not guarantee or accept any liability with respect to the correctness of information in this document. Copyright by ŠKODA AUTO A. S.



Compound breakage

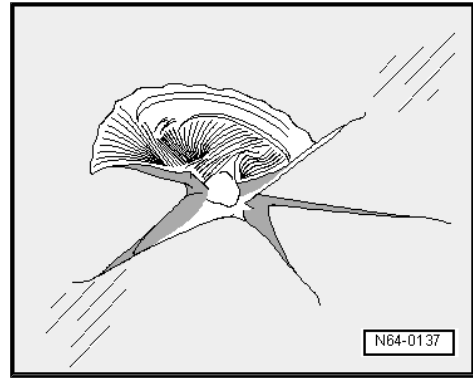

Star and crack

Description of repair

For repair work, please refer to the approved repair kit procedure in ⇒ ŠKODA AUTO a. s. workshop standards .

- ◆ Repair is carried out in a place with no direct sunlight.
- ◆ The repair site must be approximately room temperature.
- ◆ The work area must be protected from moisture.



Note

- ◆ *The vehicle is immediately ready for operation after the repair without any waiting time.*
- ◆ *Fracture residue traces can not be completely ruled out for some types of breakage and do not affect the result of the repair.*
- ◆ *After the repair, the disc is able to withstand a normal load again via the pressed and hardened plastic resin and no further cracking can occur. The cured resin is colorless and has a refractive index identical to the glass.*

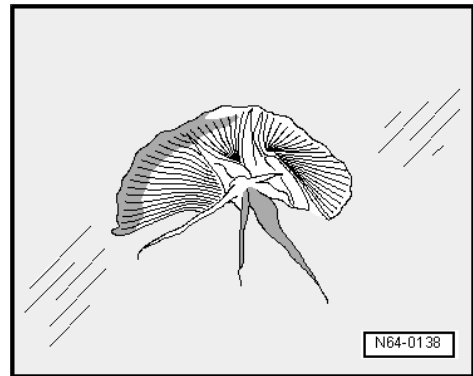

ŠKODA

Protected by copyright. Copying for private or commercial purposes, in part or in whole, is not permitted unless authorised by ŠKODA AUTO A. S. ŠKODA AUTO A. S. does not guarantee or accept any liability with respect to the correctness of information in this document. Copyright by ŠKODA AUTO A. S.

14 Repairing thread

⇒ [“14.1 Repairing thread”, page 57](#)

14.1 Repairing thread

Use a zinc-nickel coating to repair damaged threads.

Steel chips from drilling out must be removed without leaving any residue.

Only the original parts may be used.



WARNING

Only when using this coating can contact corrosion be ruled out.

Some threads are already fitted with thread inserts from the factory.

Repairing safety-relevant components

In accordance with vehicle-specific facts, it is permissible or unfeasible to carry out the necessary repairs, such as mounting for axles or safety belts.



Note

Observe the vehicle-specific repair instructions.

Protected by copyright. Copying for private or commercial purposes, in part or in whole, is not permitted unless authorised by ŠKODA AUTO A. S. ŠKODA AUTO A. S. does not guarantee or accept any liability with respect to the correctness of information in this document. Copyright by ŠKODA AUTO A. S.



15 Repairing the thread for the attachment of the assembly carrier

⇒ ["15.1 Repairing the thread for the attachment of the assembly carrier", page 58](#)

⇒ ["15.2 Contents of the thread repair set", page 60](#)

⇒ ["15.3 Drilling thread", page 60](#)

⇒ ["15.4 Cutting the thread", page 61](#)

⇒ ["15.5 Inserting the threaded insert", page 62](#)

15.1 Repairing the thread for the attachment of the assembly carrier



Caution

Observe safety instructions! ⇒ General Information; Body Repairs, General Body Repairs ; Safety measures

The assembly carrier is already removed.



Note

On this vehicle, the repair of the threads is described on the example of the front left support block for the assembly carrier and must be undertaken in the same way on the other support blocks if necessary.

Special tools and workshop equipment required

- ◆ Thread repair kit M 12x1.5 e.g. -VAS 6058-
- ◆ Drill e.g. -VAS 6267-



1 - HeliCoil threaded panel



Note

The support block must be replaced if damaged repeatedly.

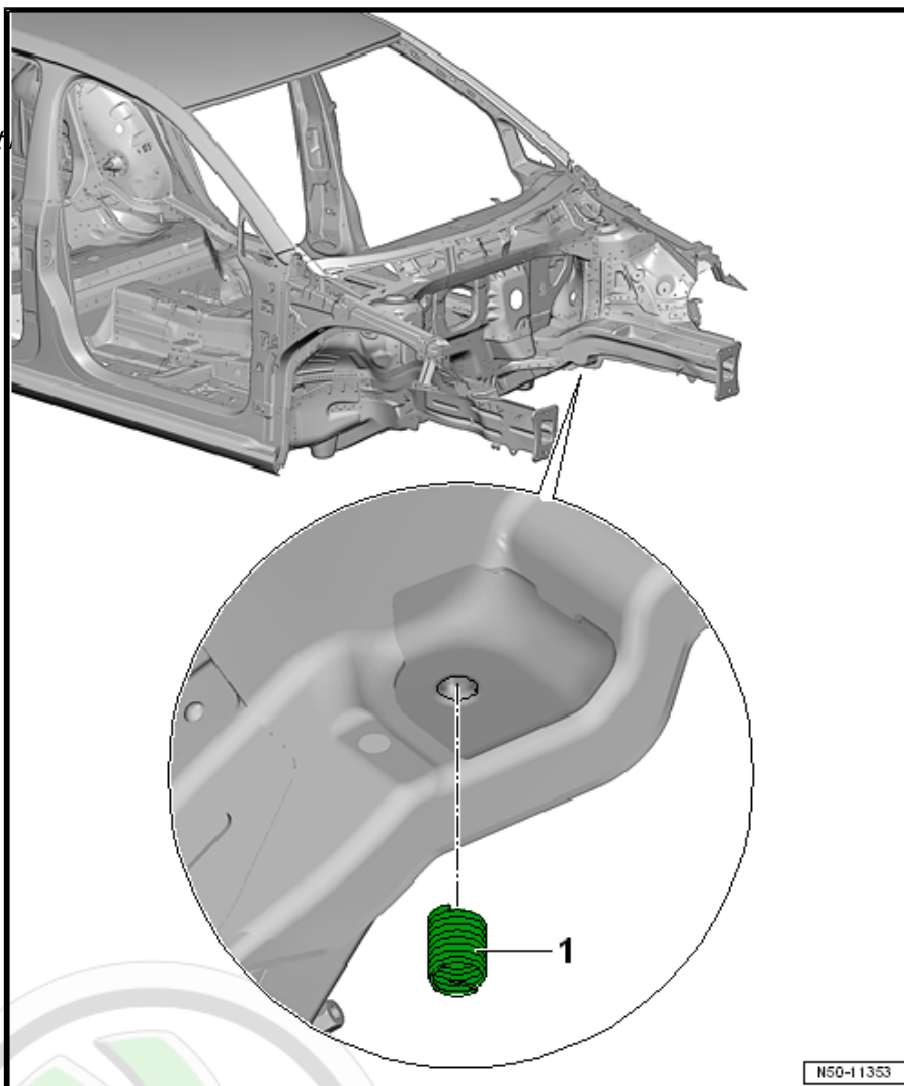

ŠKODA

Protected by copyright. Copying for private or commercial purposes, in part or in whole, is not permitted unless authorised by ŠKODA AUTO A. S. ŠKODA AUTO A. S. does not guarantee or accept any liability with respect to the correctness of information in this document. Copyright by ŠKODA AUTO A. S.



15.2 Contents of the thread repair set

- 1 - Spiral drill \varnothing 12.5 mm
- 2 - Tap drill M 12 x 1.5
- 3 - Installation spindle
- 4 - Threaded insert M 12 x 1.5 x 24 (-VAS 6058/1-)
- 5 - Pin breaker with magnetic tip

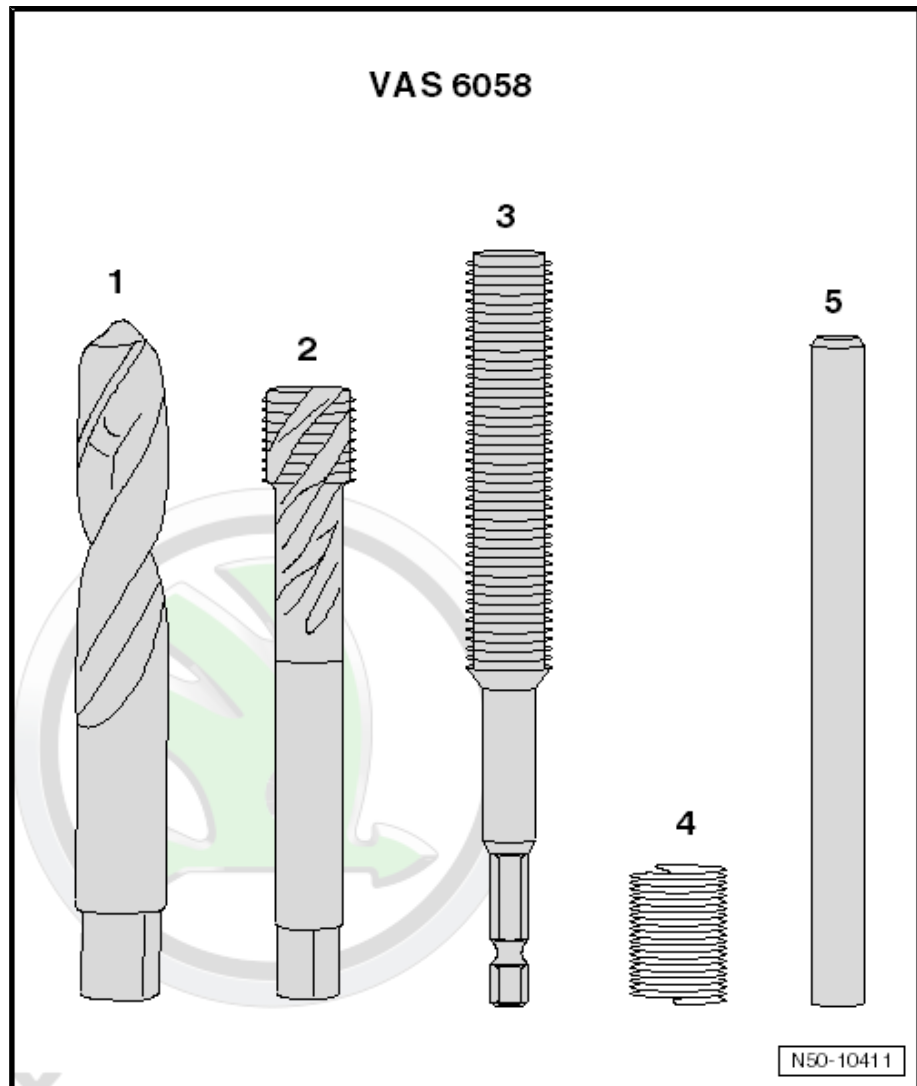

15.3 Drilling thread



Caution

Protected by copyright. Copying for private or commercial purposes, in part or in whole, is not permitted unless authorised by ŠKODA AUTO A. S. ŠKODA AUTO A. S. does not guarantee or accept any liability with respect to the correctness of information in this document. Copyright by ŠKODA AUTO A. S.

Wear safety goggles when drilling out the thread.



- Use the spiral drill for drilling out the thread.

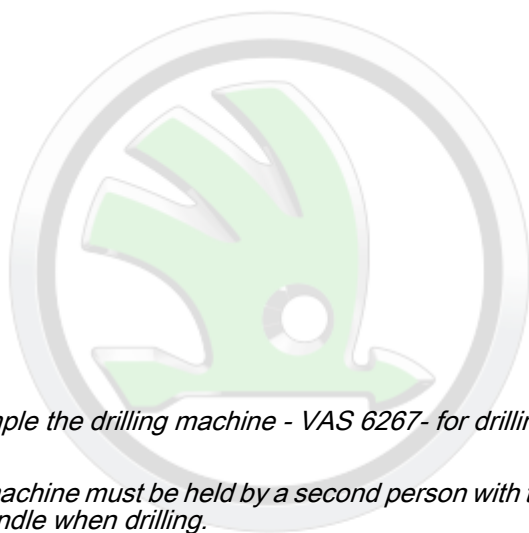

i Note

- ◆ Use for example the drilling machine - VAS 6267- for drilling and milling.
- ◆ The drilling machine must be held by a second person with the additional handle when drilling.
- ◆ Do not tilt the drill.

ŠKODA

Protected by copyright. Copying for private or commercial purposes, in part or in whole, is not permitted unless authorised by ŠKODA AUTO A. S. ŠKODA AUTO A. S. does not guarantee or accept any liability with respect to the correctness of information in this document. Copyright by ŠKODA AUTO A. S.

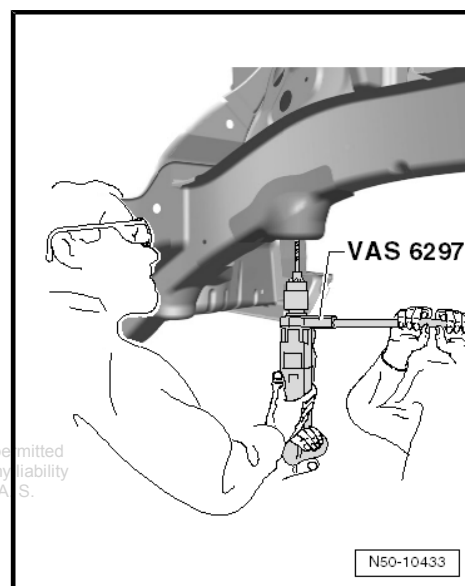
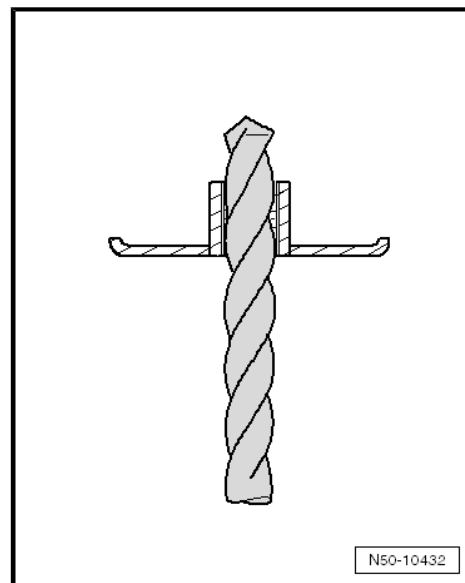

15.4 Cutting the thread



Caution

Wear safety goggles when cutting the thread and blowing out the threaded bush.



- Cut the thread with the tap drill.
- Clean the threaded bush (blow out with compressed air).

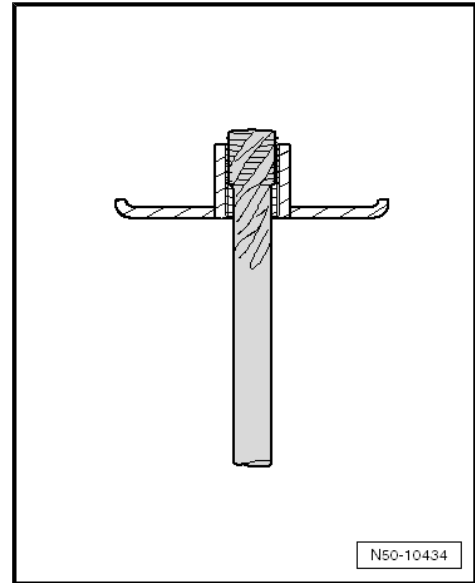

15.5 Inserting the threaded insert

- Turn the threaded insert -3- on the installation spindle until the driver pin -2- rests against the driver peg -1- of the installation spindle.



Note

It must be possible to screw in the threaded insert easily.

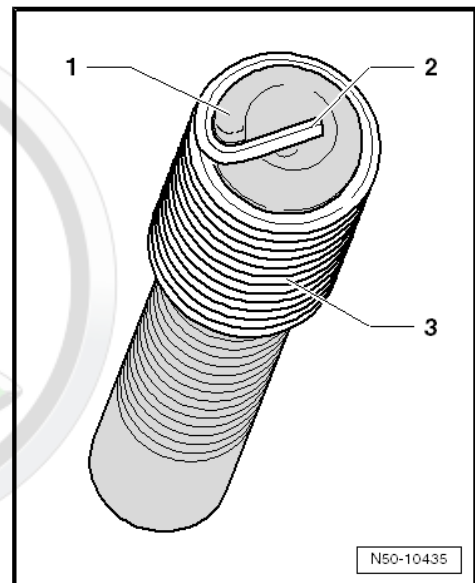

- Screw the threaded insert into the threaded plate until the threaded insert is flush with the threaded plate on the outside (visual inspection).
- Subsequently turn the threaded insert a further $\frac{1}{4}$ turn towards the inside.
- Unscrew the installation spindle.

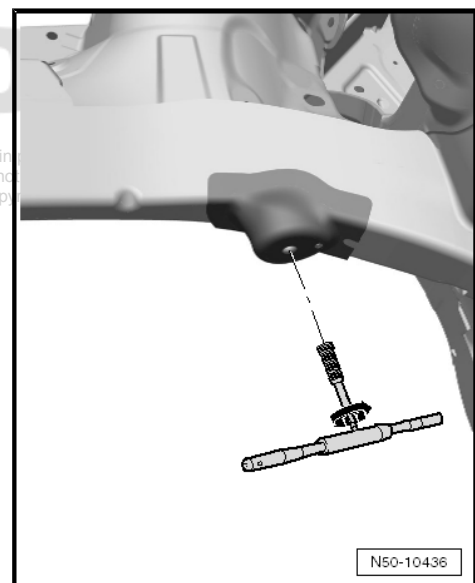



- Use the pin breaker for breaking the driver pin of the threaded insert.

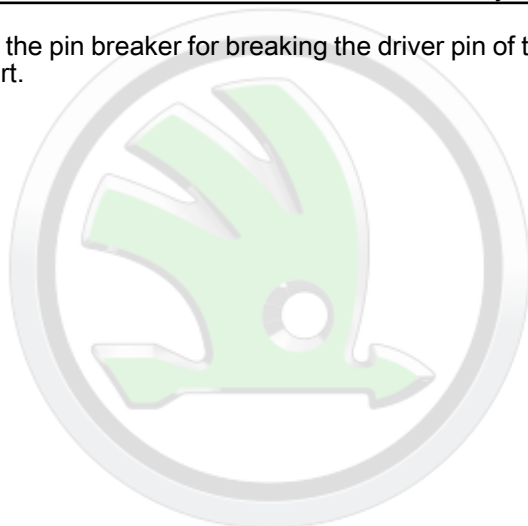

ŠKODA

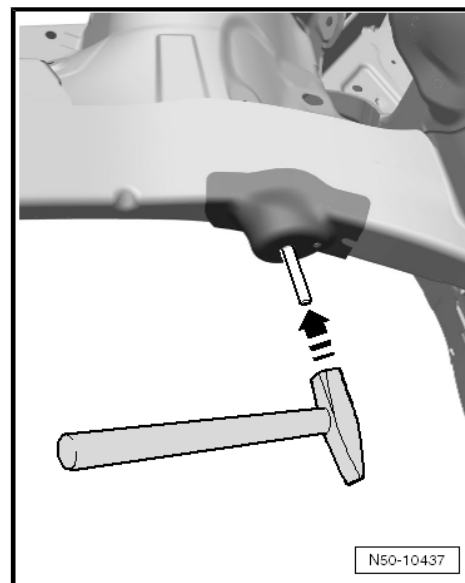

Protected by copyright. Copying for private or commercial purposes, in part or in whole, is not permitted unless authorised by ŠKODA AUTO A. S. ŠKODA AUTO A. S. does not guarantee or accept any liability with respect to the correctness of information in this document. Copyright by ŠKODA AUTO A. S.



16 Tools

⇒ ["16.1 List of tools", page 64](#)

16.1 List of tools

⇒ Škoda Auto a. s. workshop standards



ŠKODA

Protected by copyright. Copying for private or commercial purposes, in part or in whole, is not permitted unless authorised by ŠKODA AUTO A. S. ŠKODA AUTO A. S. does not guarantee or accept any liability with respect to the correctness of information in this document. Copyright by ŠKODA AUTO A. S.



17 Decorative and protective foils

⇒ ["17.1 Decorative and protective foils", page 65](#)

⇒ ["17.2 Training videos", page 65](#)

17.1 Decorative and protective foils

Do not glue foils to newly painted vehicles.

- Before gluing on the foil, the fresh paint should evaporate for approximately 3 weeks at an average temperature of 20 °C.



Note

E.g., the damaged roof film can be replaced by paint on the Octavia III RS model with tilting sunroof

⇒ ["17.2 Training videos", page 65](#).

17.2 Training videos

Videos are part of an E-learning course, stored on the training platform e.g. ⇒ CMP or ⇒ CTO and similar.

ŠKODA

Protected by copyright. Copying for private or commercial purposes, in part or in whole, is not permitted unless authorised by ŠKODA AUTO A. S. ŠKODA AUTO A. S. does not guarantee or accept any liability with respect to the correctness of information in this document. Copyright by ŠKODA AUTO A. S.